

**Agilent IO Libraries Suite
E2094Q**

**Agilent VISA
User's Guide for IO
Libraries Suite 15**



Agilent Technologies

Notices

© Agilent Technologies, Inc. 71995-1996, 1998, 2000-2007

No part of this manual may be reproduced in any form or by any means (including electronic storage and retrieval or translation into a foreign language) without prior agreement and written consent from Agilent Technologies, Inc. as governed by United States and international copyright laws.

Manual Part Number

5989-6135EN

Edition

Ninth edition, October 2007

Agilent Technologies, Inc.
815 14th Street SW
Loveland, CO 80537 USA

Trademark Information

Visual Studio is a registered trademark of Microsoft Corporation in the United States and other countries.

Windows NT is a U.S. registered trademark of Microsoft Corporation.

Windows and MS Windows are U.S. registered trademarks of Microsoft Corporation.

Software Revision

This guide is valid for Revisions 15.xx of the Agilent IO Libraries Suite software, where xx refers to minor revisions of the software that do not affect the technical accuracy of this guide.

Warranty

The material contained in this document is provided “as is,” and is subject to being changed, without notice, in future editions. Further, to the maximum extent permitted by applicable law, Agilent disclaims all warranties, either express or implied, with regard to this manual and any information contained herein, including but not limited to the implied warranties of merchantability and fitness for a particular purpose. Agilent shall not be liable for errors or for incidental or consequential damages in connection with the furnishing, use, or performance of this document or of any information contained herein. Should Agilent and the user have a separate written agreement with warranty terms covering the material in this document that conflict with these terms, the warranty terms in the separate agreement shall control.

Technology Licenses

The hardware and/or software described in this document are furnished under a license and may be used or copied only in accordance with the terms of such license.

Restricted Rights Legend

If software is for use in the performance of a U.S. Government prime contract or subcontract, Software is delivered and licensed as “Commercial computer software” as defined in DFAR 252.227-7014 (June 1995), or as a “commercial item” as defined in FAR 2.101(a) or as “Restricted computer software” as defined in FAR 52.227-19 (June 1987) or any equivalent agency regulation or contract clause. Use, duplication or disclosure of Software is subject to Agilent Technologies’ standard commercial license terms, and non-DOD Departments and Agencies of the U.S.

Government will receive no greater than Restricted Rights as defined in FAR 52.227-19(c)(1-2) (June 1987). U.S. Government users will receive no greater than Limited Rights as defined in FAR 52.227-14 (June 1987) or DFAR 252.227-7015 (b)(2) (November 1995), as applicable in any technical data.

Safety Notices

CAUTION

A **CAUTION** notice denotes a hazard. It calls attention to an operating procedure, practice, or the like that, if not correctly performed or adhered to, could result in damage to the product or loss of important data. Do not proceed beyond a **CAUTION** notice until the indicated conditions are fully understood and met.

WARNING

A **WARNING** notice denotes a hazard. It calls attention to an operating procedure, practice, or the like that, if not correctly performed or adhered to, could result in personal injury or death. Do not proceed beyond a **WARNING** notice until the indicated conditions are fully understood and met.

Agilent VISA User's Guide

1 Introduction

What's in This Guide?	8
VISA Overview	9
Using VISA, VISA COM, and SICL	9
VISA Support	10
VISA Documentation	10
Contacting Agilent	12

2 Building a VISA Application in Windows

Building a VISA Program (C/C++)	14
Compiling and Linking VISA Programs (C/C++)	14
Sample VISA Program (C/C++)	15
Building a VISA Program (Visual Basic)	18
Visual Basic Programming Considerations	18
Sample VISA Program (Visual Basic)	20
Logging Error Messages	25
Using the Event Viewer	25
Using the Debug Window	25

3 Programming with VISA

VISA Resources and Attributes	28
VISA Resources	28
VISA Attributes	29
Using Sessions	31
Including the VISA Declarations File (C/C++)	31
Adding the visa32.bas File (Visual Basic)	31
Opening a Session	32
Addressing a Session	34

Closing a Session	39
Searching for Resources	39
Sending I/O Commands	42
Types of I/O	42
Using Formatted I/O	42
Using Non-Formatted I/O	53
Using Events and Handlers	56
Events and Attributes	56
Using the Callback Method	64
Using the Queuing Method	73
Trapping Errors	78
Trapping Errors	78
Exception Events	79
Using Locks	84
Lock Functions	84
viLock/viUnlock Functions	84
VISA Lock Types	85

4 Programming via GPIB and VXI

GPIB and VXI Interfaces Overview	92
General Interface Information	92
GPIB Interfaces Overview	93
VXI Interfaces Overview	96
GPIB-VXI Interfaces Overview	97
Using High-Level Memory Functions	100
Programming the Registers	100
High-Level Memory Functions: Sample Programs	102
Using Low-Level Memory Functions	106
Programming the Registers	106
Low-Level Memory Functions: Code Samples	109

Using Low/High-Level Memory I/O Methods	112
Using Low-Level viPeek/viPoke	112
Using High-Level viIn/viOut	113
Using High-Level viMoveIn/viMoveOut	113
Using the Memory Access Resource	118
Memory I/O Services	118
MEMACC Attribute Descriptions	121
Using VXI-Specific Attributes	125
Using the Map Address as a Pointer	125
Setting the VXI Trigger Line	126

5 Programming via LAN

LAN and Remote Interfaces Overview	130
Direct LAN Connection versus Remote IO Server/Client Connection	130
Remote IO Server/Client Architecture	130
Addressing LAN-Connected Devices	133
Using the TCPIP Interface Type for LAN Access	133
Using a Remote Interface for LAN Access	136

6 Programming via USB

USB Interfaces Overview	140
Communicating with a USB Instrument Using VISA	141

Glossary

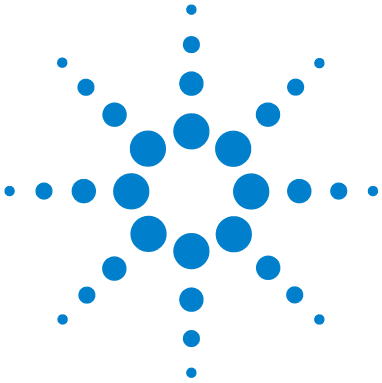

1

Introduction

This *Agilent VISA User's Guide* describes the Agilent Virtual Instrument Software Architecture (VISA) library and shows how to use it to develop I/O applications and instrument drivers on Windows PCs.

NOTE

Before you can use VISA, you must install and configure VISA on your computer. See the *Agilent IO Libraries Suite Connectivity Guide with IO Libraries Getting Started* for installation on Windows systems.

Note that using VISA functions and SICL functions in the same I/O application is not supported.

This chapter includes:

- What's In This Guide?
- VISA Overview
- Contacting Agilent



What's in This Guide?

This guide shows VISA programming techniques using C/C++ and Visual Basic. This chapter provides an overview of VISA and shows how to contact Agilent Technologies. Subsequent chapters in this guide address the following topics:

- *Chapter 2 - Building a VISA Application in Windows* describes how to build a VISA application in a Windows environment. A sample program is provided to help you get started programming with VISA.
- *Chapter 3 - Programming with VISA* describes the basics of VISA and lists some sample programs. The chapter also includes information on creating sessions, using formatted I/O, events, etc.
- *Chapter 4 - Programming via GPIB and VXI* provides guidelines for using VISA to communicate over the GPIB, GPIB-VXI, and VXI interfaces to instruments.
- *Chapter 5 - Programming via LAN* provides guidelines for using VISA to communicate over a LAN (Local Area Network) to instruments.
- *Chapter 6 - Programming via USB* provides guidelines for using VISA to communicate over a USB (Universal Serial Bus) to instruments.
- *Glossary* includes a glossary of terms and their definitions.

See "[VISA Documentation](#)" on page 10 for other sources of information on VISA programming.

VISA Overview

VISA is an application programming interface (API) for instrument control. It allows you to programmatically send commands and receive data from instruments and other test and measurement devices (such as sources and switches).

VISA is a part of the Agilent IO Libraries Suite product. The Agilent IO Libraries Suite includes three libraries: *Agilent Virtual Instrument Software Architecture (VISA)*, *VISA for the Common Object Model (VISA COM)*, and *Agilent Standard Instrument Control Library (SICL)*. This guide describes Agilent VISA for supported Windows environments.

For information on VISA COM, see the online Help on VISA COM, available by clicking the blue IO Control icon on your screen (if you have installed Agilent IO Libraries Suite). For information on using SICL in Windows, see the *Agilent SICL User's Guide for Windows*. For information on Agilent IO Libraries Suite, see the *Agilent IO Libraries Suite Connectivity Guide with IO Libraries Getting Started* and the *Agilent IO Libraries Suite Online Help*.

Using VISA, VISA COM, and SICL

Agilent Virtual Instrument Software Architecture (VISA) is an I/O library designed according to the VXI*plug&play* System Alliance that allows software developed from different vendors to run on the same system.

If you are using new instruments or are developing new I/O applications or instrument drivers, and you have chosen to use direct I/O rather than instrument drivers, we recommend you use Agilent VISA or VISA COM. See the *Agilent IO Libraries Suite Online Help* for an in-depth discussion of your programming options.

Agilent Standard Instrument Control Library (SICL) is an I/O library developed by Agilent that is portable across many I/O interfaces and systems. You can use Agilent SICL if you have been using SICL and want to remain compatible with software currently implemented in SICL.

VISA Support

This 32-bit version of VISA is supported on Microsoft Windows 2000 and Windows XP. (For information on support of older operating systems, see the *Agilent IO Libraries Suite Online Help*.) C, C++, and Visual Basic are supported on these Windows versions. C# and Visual Basic .NET are also supported via the `visa32.cs` and `visa32.vb` header files that are included with the Agilent VISA library.

VISA is supported on the GPIB, VXI, GPIB-VXI, Serial (RS-232), LAN, and USB interfaces. LAN support from within VISA occurs via an address translation such that a GPIB interface can be accessed remotely over a computer network.

Agilent VISA provides support for version 3.0 of the VISA specification.

VISA Documentation

This table shows associated documentation you can use when programming with Agilent VISA.

Table 1 Agilent VISA Documentation

Document	Description
<i>Agilent IO Libraries Suite Connectivity Guide with IO Libraries Getting Started</i>	Shows how to install, configure, and maintain Agilent IO Libraries Suite.
<i>VISA Online Help</i>	A function reference and other programming information is provided in the form of Windows Help.
<i>VISA Sample Programs</i>	Sample programs are provided online to help you develop VISA applications.
<i>VXIplug&play System Alliance VISA Library Specification 4.3</i>	Specifications for VISA.
<i>IEEE Standard Codes, Formats, Protocols, and Common Commands</i>	ANSI/IEEE Standard 488.2-1992.

Table 1 Agilent VISA Documentation

<i>VXIbus Consortium specifications (when using VISA over LAN)</i>	<i>TCP/IP Instrument Protocol Specification - VXI-11, Rev. 1.0</i> <i>TCP/IP-VXIbus Interface Specification - VXI-11.1, Rev. 1.0</i> <i>TCP/IP-IEEE 488.1 Interface Specification - VXI-11.2, Rev. 1.0</i> <i>TCP/IP-IEEE 488.2 Instrument Interface Specification - VXI-11.3, Rev. 1.0</i>
--	--

Contacting Agilent

- In the USA, you can reach Agilent Technologies by telephone at:
USA: 1-800-829-4444
- Outside the USA, contact your country's Agilent support organization. A list of contact information for other countries is available on the Agilent Web site:

<http://www.agilent.com/find/assist>

- The Agilent Developer Network (ADN),

<http://www.agilent.com/find/adn>

is a one-stop web resource that supports your connectivity needs with software downloads, sample code, technical notes and white papers.



2 Building a VISA Application in Windows

This chapter provides guidelines for building a VISA application in a Windows environment.

The chapter contains the following sections:

- Building a VISA Program (C/C++)
- Building a VISA Program (Visual Basic)
- Logging Error Messages

For information on building a VISA application in Visual Studio .NET, see the *VISA Online Help*.



Building a VISA Program (C/C++)

This section provides guidelines for building VISA programs using the C/C++ language, including:

- Compiling and Linking VISA Programs (C/C++)
- Sample VISA Program (C/C++)

Compiling and Linking VISA Programs (C/C++)

This section provides a summary of important compiler-specific considerations when developing Win32 applications.

Linking to VISA Libraries

Your application must link to the VISA import library as follows, assuming default installation directories and Microsoft compilers:

```
C:\Program Files\VISA\winnt\lib\msc\visa32.lib
```

The following steps will help you do this. This information is specific to your development environment.

Microsoft Visual C++ Version 6.0 Development Environment

- 1 Use the **File** menu to create a new project or open an existing project.
- 2 Select **Project > Settings** from the menu and click the **C/C++** tab.
- 3 Select **Code Generation** from the **Category** list box and select **Multi-Threaded using DLL** from the **Use Run-Time Libraries** list box. (VISA requires these definitions for Win32.) Click **OK** to close the dialog box.
- 4 Select **Project > Settings** from the menu. Click the **Link** tab and add `visa32.lib` to the **Object/Library Modules** list box. Optionally, you may add the library directly to your project file. Click **OK** to close the dialog box.
- 5 You may want to add the *include files* and *library files* search paths. They are set as follows:
 - Select **Tools > Options** from the menu.
 - Click the **Directories** tab to set the include file path.
 - Select **Include Files** from the **Show Directories For** list box.

- Click at the bottom of the list box and type:
C:\Program Files\VISA\winnt\include
(This assumes that you used the default installation location for VISA.)
 - Select **Library Files** from the **Show Directories For** list box.
 - Click at the bottom of the list box and type:
C:\Program Files\VISA\winnt\lib\msc
(This assumes that you used the default installation location for VISA.)
- 6** Add or create your C or C++ source files. For example, to build the sample described below, select **Project > Add to Project > Files...** and type or browse to C:\Program Files\Agilent\IO Libraries Suite\ProgrammingSamples\C\VISA\idn.c.
- 7** Click **Build > Rebuild All** to build the VISA program.

Microsoft Visual Studio .NET

For information on building a VISA application in Visual Studio .NET, see the *VISA Online Help*.

Sample VISA Program (C/C++)

This section lists a sample program called **idn** that queries a GPIB instrument for its identification string. This sample assumes a Win32 console application using Microsoft Visual Studio® on Windows.

The **idn** sample files are in the `ProgrammingSamples` directory under the Agilent IO Libraries Suite installation directory. By default, the sample files are in

```
C:\Program Files\Agilent\IO Libraries Suite\
ProgrammingSamples\C\VISA.
```

Sample C/C++ Program Source Code

The source file `idn.c` follows. An explanation of the various function calls in the sample is provided directly after the program listing. If the program runs correctly and your PC is connected to a 54622A oscilloscope, the following is an example of the program output.

AGILENT TECHNOLOGIES,54622A,987654312,A.01.50

2 Building a VISA Application in Windows

If the program does not run, see the **Event Viewer** for a list of run-time errors.

```
/*idn.c
   This example program queries a GPIB device for
   an identification string and prints the
   results. Note that you must change the address.
*/

#include <visa.h>
#include <stdio.h>

void main () {

    ViSession defaultRM, vi;
    char buf [256] = {0};

    /* Open session to GPIB device at address 22 */
    viOpenDefaultRM(&defaultRM);
    viOpen(defaultRM,
"GPIB0::22::INSTR",VI_NULL,VI_NULL,
    &vi);

    /* Initialize device */
    viPrintf(vi, "*RST\n");
    /* Send an *IDN? string to the device */
    viPrintf(vi, "*IDN?\n");
    /* Read results */
    viScanf(vi, "%t", buf);

    /* Print results */
    printf("Instrument identification string:
%s\n", buf);

    /* Close session */
    viClose(vi);
    viClose(defaultRM);}

```

C/C++ Sample Program Contents

A summary of the VISA function calls used in the preceding sample C/C++ program follows. For a more detailed explanation of VISA functionality, see [Chapter 3](#), “Programming with VISA.” See the *VISA Online Help* for more detailed information on these VISA function calls.

Table 2 Summary of VISA Function Calls Used in the C/C++ Sample

Function(s)	Description
<code>visa.h</code>	This file is included at the beginning of the program to provide the function prototypes and constants defined by VISA.
ViSession	The ViSession is a VISA data type. Each object that will establish a communication channel must be defined as ViSession .
viOpenDefaultRM	You must first open a session with the default resource manager with the viOpenDefaultRM function. This function will initialize the default resource manager and return a pointer to that resource manager session.
viOpen	This function establishes a communication channel with the device specified. A session identifier that can be used with other VISA functions is returned. This call must be made for each device you will be using.
viPrintf and viScanf	These are the VISA formatted I/O functions that are patterned after those used in the C programming language. The viPrintf call sends the IEEE 488.2 *RST command to the instrument and puts it in a known state. The viPrintf call is used again to query for the device identification (*IDN?). The viScanf call is then used to read the results.
viClose	This function must be used to close each session. When you close a device session, all data structures that had been allocated for the session will be deallocated. When you close the default manager session, all sessions opened using that default manager session will be closed.

Building a VISA Program (Visual Basic)

This section provides guidelines for building a VISA program in the Microsoft Visual Basic (VB) language, including:

- Visual Basic Programming Considerations
- Sample VISA Program (Visual Basic)

Visual Basic Programming Considerations

Some considerations for programming in Visual Basic follow. This information applies to Microsoft Visual Basic version 6.0; for information on building a VISA application in Microsoft Visual Studio .NET, see the *VISA Online Help*.

Required Module for a Visual Basic VISA Program

Before you can use VISA specific functions, your application must add the `visa32.bas` VISA Visual Basic module found in `C:\Program Files\VISA\winnt\include\` (assuming default installation directories).

Adding the `visa32.bas` File to Your Project

To install `visa32.bas`:

- 1 Select **Project > Add Module** from the Visual Basic 6.0 menu.
- 2 Select the **Existing** tab.
- 3 Browse and select the `visa32.bas` file from the applicable directory (by default, `C:\Program Files\VISA\winnt\include\`).
- 4 Click the **Open** button.

VISA Limitations in Visual Basic

VISA functions return a status code that indicates success or failure of the function. The only indication of an error is the value of a returned status code. The VB **Error** variable is not set by any VISA function. Thus, you cannot use the **ON ERROR** construct in VB or the value of the VB **Error** variable to catch VISA function errors.

VISA cannot call back to a VB function. Thus, you can only use the **VI_QUEUE** mechanism in **viEnableEvent**. There is no way to install a VISA event handler in VB.

VISA functions that take a variable number of parameters (**viPrintf**, **viScanf**, **viQueryf**) are not callable from VB. Use the corresponding **viVPrintf**, **viVScanf** and **viVQueryf** functions instead.

You cannot pass variables of type **Variant** to VISA functions. If you attempt this, the Visual Basic program will probably crash with a 'General Protection Fault' or an 'Access Violation.'

Format Conversion Commands

The functions **viVPrintf**, **viVScanf** and **viVQueryf** can be called from VB, but there are restrictions on the format conversions that can be used. Only one format conversion command can be specified in a format string (a format conversion command begins with the % character).

For example, the following is invalid:

```
status = viVPrintf(vi, "%lf%d" + Chr$(10),
...)
```

Instead, you must make one call for each format conversion command, as shown in the following example:

```
status = viVPrintf(vi, "%lf" + Chr$(10),
dbl_value)
status = viVPrintf(vi, "%d" + Chr$(10),
int_value)
```

Numeric Arrays

When reading from or writing to a numeric array, you must specify the first element of a numeric array as the *params* parameter. This passes the address of the first array element to the function. For example, the following code declares an array of 50 floating point numbers and then calls **viVPrintf** to write from the array.

```
Dim flt_array(50) As Double
status = viVPrintf(id, "%,50f", dbl_array(0))
```

Strings

When reading in a string value with `viVScanf` or `viVQueryf`, you must pass a fixed length string as the *params* parameter. To declare a fixed length string, instead of using the normal variable length declaration:

```
Dim strVal as String
```

use the following declaration, where 40 is the fixed length.

```
Dim strVal as String * 40
```

Sample VISA Program (Visual Basic)

This section lists a sample program called `idn` that queries a GPIB instrument for its identification string. This sample builds a standard `.exe` application for WIN32 programs using the Visual Basic 6.0 programming language.

Assuming default installation directories, the `idn` sample files are in `C:\Program Files\Agilent\IO Libraries Suite\ProgrammingSamples\VB6\VISA\IDN`

Steps to Running the Program

The steps to building and running the `idn` sample program follow.

- 1 Connect an instrument to a GPIB interface that is compatible with IEEE 488.2.
- 2 Start the Visual Basic 6.0 application.

NOTE

This example assumes you are building a new project (no `.vbp` file exists for the project). If you do not want to build the project from scratch, from the menu select **File > Open Project...** and select and open the `idn.vbp` file. Then skip to Step 7.

- 3 Start a new Visual Basic Standard `.exe` project. VB 6.0 will open a new project, **Project1**, with a blank Form, **Form1**.
- 4 From the menu, select **Project > Add Module**, select the **Existing** tab, and browse to the `idn` directory. If you used default installation paths, this directory is `C:\Program Files\Agilent\IO`

Libraries Suite\ProgrammingSamples\VB6\VISA\idn.

- 5 Select the file `idn.bas` and click **Open**. Since the **Main()** subroutine is executed when the program is run without requiring user interaction with a Form, you may delete **Form1** if desired. To do this, right-click **Form1** in the Project Explorer window and select **Remove Form1**.
- 6 VISA applications in Visual Basic require the VISA Visual Basic (VB) declaration file `visa32.bas` in your VB project. This file contains the VISA function definitions and constant declarations needed to make VISA calls from Visual Basic. To add this module to your project in VB 6.0, from the menu select **Project > Add Module**, select the **Existing** tab, browse to the directory containing the VB declaration file (by default, this is `C:\Program Files\VISA\winnt\include\`), select `visa32.bas`, and click **Open**.
- 7 At this point, you can run and debug the Visual Basic project. You may need to change the VISA interface name and address in the code to match your device's configuration.
- 8 If you want to compile to an executable file, from the menu select **File > Make idn.exe...** and click **OK**. This will create `idn.exe` in the **idn** directory.

Sample Program Source Code

An explanation of the various function calls in the sample is provided after this program listing. If the program runs correctly, the following is an example of the output that appears in a message box if your PC is connected to a 54601A oscilloscope.

HEWLETT-PACKARD,54601A,0,1.7

2 Building a VISA Application in Windows

If the program does not run, see the **Event Viewer** for a list of run-time errors. The source file `idn.bas` follows.

```
Option Explicit
' ..
' ..
' idn.bas
' This example program queries a GPIB device for
' an identification string and prints the
' results. Note that you may have to change the
' VISA Interface Name and address for your
' device from "GPIB0" and "22", respectively.
' ..
' ..

Sub Main()
    Dim defrm As Long 'Session to Default
    Resource Manager
    Dim vi As Long 'Session to instrument
    Dim strRes As String * 200 'Fixed length
    string to hold results

    ' Open the default resource manager session
    Call viOpenDefaultRM(defrm)
    ' Open the session to the resource
    ' The "GPIB0" parameter is the VISA Interface
    ' name to a
    ' GPIB instrument as defined in
    ' Connection Expert.
    ' Change this name to what you have defined
    ' for your VISA Interface.
    ' "GPIB0::22::INSTR" is the address string
    ' for the device.
    ' this address will be the same as seen in:
    ' Connection Expert)
```

```

Call viOpen(defrm, "GPIB0::22::INSTR", 0, 0,
vi)

' Initialize device
Call viVPrintf(vi, "*RST" + Chr$(10), 0)

' Ask for the device's *IDN string.
Call viVPrintf(vi, "*IDN?" + Chr$(10), 0)

' Read the results as a string.
Call viVScanf(vi, "%t", strRes)

' Display the results
MsgBox "Result is: " + strRes, vbOKOnly,
"*IDN? Result"

' Close the vi session and the resource
  manager session
Call viClose(vi)
Call viClose(defrm)
End Sub

```

Sample Program Contents

A summary of the VISA function calls used in the preceding sample Visual Basic program follows. For a more detailed explanation of VISA functionality, see [Chapter 3](#), “Programming with VISA.” See the *VISA Online Help* for more detailed information on these VISA function calls.

Table 3 Summary of VISA Function Calls in Visual Basic Sample

Function(s)	Description
viOpenDefaultRM	You must first open a session with the default resource manager with the viOpenDefaultRM function. This function will initialize the default resource manager and return a pointer (<i>defrm</i>) to that resource manager session.

2 Building a VISA Application in Windows

Table 3 Summary of VISA Function Calls in Visual Basic Sample

viOpen	This function establishes a communication channel with the device specified. A session identifier (vi) that can be used with other VISA functions is returned. This call must be made for each device you will be using.
viVPrintf and viVScanf	These are the VISA formatted I/O functions. The viVPrintf call sends the IEEE 488.2 *RST command to the instrument (plus a linefeed character) and puts it in a known state. The viVPrintf call is used again to query for the device identification (*IDN?). The viVScanf call is then used to read the results (strRes) that are displayed in a Message Box.
viClose	This function must be used to close each session. When you close a device session, all data structures that had been allocated for the session will be deallocated. When you close the default manager session, all sessions opened using that default manager session will be closed.

Logging Error Messages

When developing or debugging your VISA application, you may want to view internal VISA messages while your application is running. You can do this by using the **Event Viewer** utility or the **Debug Window**. There are three choices for VISA logging:

- **Off** (default) for best performance
- **Event Viewer**
- **Debug Window**

Using the Event Viewer

The **Event Viewer** utility provides a way to view internal VISA error messages during application execution. Some of these internal messages do not represent programming errors; they indicate events which are being handled internally by VISA. The process for using the **Event Viewer** is:

- Enable VISA logging from the Agilent IO Control by clicking the blue **IO** icon on the taskbar and then clicking **Agilent VISA Options > VISA Logging > Event Viewer**.
- Run your VISA program.
- View VISA error messages by running the **Event Viewer**. From the Agilent IO Control, click **Event Viewer**. VISA error messages will appear in the application log of the **Event Viewer** utility.

Using the Debug Window

When VISA logging is directed to the **Debug Window**, VISA writes logging messages using the Win32 API call **OutputDebugString()**. The most common use for this feature is when debugging your VISA

2 Building a VISA Application in Windows

program using an application such as Microsoft Visual Studio. In this case, VISA messages will appear in the Visual Studio output window. The process for using the **Debug Window** is:

- 1 Enable VISA logging from the Agilent IO Control by clicking the blue **IO** icon on the taskbar and then clicking **Agilent VISA Options > VISA Logging > Debug Window**.
- 2 Run your VISA program from Microsoft Visual Studio (or equivalent application).
- 3 View error messages in the Visual Studio (or equivalent) output window.

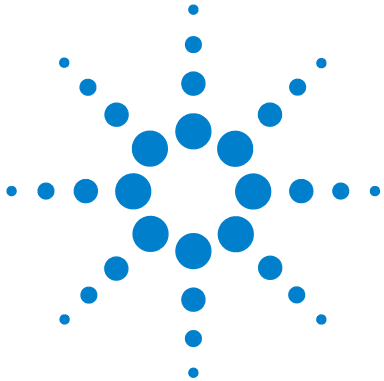

3 Programming with VISA

This chapter describes how to program with VISA. The basics of VISA are described, including formatted I/O, events and handlers, attributes, and locking. Sample programs are also provided and can be found in the ProgrammingSamples subdirectory (C:\Program Files\Agilent\IO Libraries Suite\ProgrammingSamples in a default installation).

Click the IO Control and select **Installation Information** to see the specific installation directories used on your PC. For specific details on VISA functions, see the *VISA Online Help*.

This chapter contains the following sections:

- VISA Resources and Attributes
- Using Sessions
- Sending I/O Commands
- Using Events and Handlers
- Trapping Errors
- Using Locks



VISA Resources and Attributes

This section introduces VISA resources and attributes, including:

- VISA Resources
- VISA Attributes

VISA Resources

In VISA, a **resource** is defined as any device (such as a voltmeter) with which VISA can provide communication. VISA defines six **resource classes** that a complete VISA system, fully compliant with the *VXIplug&play Systems Alliance* specification, can implement. Each resource class includes:

- **Attributes** to determine the state of a resource or session or to set a resource or session to a specified state.
- **Events** for communication with applications.
- **Operations** (functions) that can be used for the resource class.

A summary description of each resource class supported by Agilent VISA follows. See *VISA Resource Classes* in the *VISA Online Help* for a description of the attributes, events, and operations for each resource class.

NOTE

Although the Servant Device-Side (SERVANT) resource is defined by the VISA specification, the SERVANT resource is not supported by Agilent VISA. The SERVANT Resource is intended for advanced users who need to write code that causes a computer to function as an instrument rather than as a controller.

Table 4 Descriptions of Resource Classes Supported by Agilent VISA

Resource Class	Interface Types	Resource Class Description
Instrument Control (INSTR)	Generic, GPIB, GPIB-VXI, Serial, TCPIP, USB, VXI	Device operations (reading, writing, triggering, etc.).

Table 4 Descriptions of Resource Classes Supported by Agilent VISA

GPIB Bus Interface (INTFC)	Generic, GPIB	Raw GPIB interface operations (reading, writing, triggering, etc.).
Memory Access (MEMACC)	Generic, GPIB-VXI, VXI	Address space of a memory-mapped bus such as the VXIbus.
VXI Mainframe Backplane (BACKPLANE)	Generic, GPIB-VXI, VXI (GPIB-VXI BACKPLANE not supported)	VXI-defined operations and properties of each backplane (or chassis) in a VXIbus system.
TCPIP Socket (SOCKET)	Generic, TCPIP	Operations and properties of a raw network socket connection using TCPIP.

VISA Attributes

Attributes are associated with **resources** or **sessions**. You can use attributes to determine the state of a resource or session, or to set a resource or session to a specified state.

For example, you can use the **viGetAttribute** function to read the state of an attribute for a specified session, event context, or find list. There are read only (RO) and read/write (RW) attributes. Use the **viSetAttribute** function to modify the state of a read/write attribute for a specified session, event context, or find list.

The pointer passed to **viGetAttribute** must point to the exact type required for that attribute (**ViUInt16**, **ViInt32**, etc.). For example, when reading an attribute state that returns a **ViUInt16**, you must declare a variable of that type and use it for the returned data. If **ViString** is returned, you must allocate an array and pass a pointer to that array for the returned data.

Sample: Reading a VISA Attribute

This code sample reads the state of the `VI_ATTR_TERMCHAR_EN` attribute and changes it if it is not true.

3 Programming with VISA

```
ViBoolean state, newstate;
newstate=VI_TRUE;
viGetAttribute(vi, VI_ATTR_TERMCHAR_EN, &state);
if (state err !=VI_TRUE) viSetAttribute(vi,
    VI_ATTR_TERMCHAR_EN, newstate);
```

Using Sessions

This section shows how to use VISA sessions, including:

- Including the VISA Declarations File (C/C++)
- Adding the `visa32.bas` File (Visual Basic)
- Opening a Session to a Resource
- Addressing a Session
- Closing a Session
- Searching for Resources

Including the VISA Declarations File (C/C++)

For C and C++ programs, you must include the `visa.h` header file at the beginning of every file that contains VISA function calls:

```
#include "visa.h"
```

This header file contains the VISA function prototypes and the definitions for all VISA constants and error codes. The `visa.h` header file also includes the `visatype.h` header file.

The `visatype.h` header file defines most of the VISA types. The VISA types are used throughout VISA to specify data types used in the functions. For example, the **viOpenDefaultRM** function requires a pointer to a parameter of type **ViSession**. If you find **ViSession** in the `visatype.h` header file, you will find that **ViSession** is eventually typed as an unsigned long. VISA types are also listed in *VISA System Information* in the *VISA Online Help*.

Adding the `visa32.bas` File (Visual Basic)

You must add the `visa32.bas` Basic module file to your Visual Basic project. The `visa32.bas` file contains the VISA function prototypes and definitions for all VISA constants and error codes.

Opening a Session

A **session** is a channel of communication. Sessions must first be opened on the default resource manager, and then for each resource you will be using.

- A **resource manager session** is used to initialize the VISA system. It is a parent session that knows about all the opened sessions. A resource manager session must be opened before any other session can be opened.
- A **resource session** is used to communicate with a resource on an interface. A session must be opened for each resource you will be using. When you use a session you can communicate without worrying about the type of interface to which it is connected. This insulation makes applications more robust and portable across interfaces.

Resource Manager Sessions

There are two parts to opening a communications session with a specific resource. First, you must open a session to the default resource manager with the **viOpenDefaultRM** function. The first call to this function initializes the default resource manager and returns a session to that resource manager session. You only need to open the default manager session once. However, subsequent calls to **viOpenDefaultRM** return a unique session to the same default resource manager resource.

Resource Sessions

Next, open a session with a specific resource using the **viOpen** function. This function uses the session returned from **viOpenDefaultRM** and returns its own session to identify the resource session. The following shows the function syntax.

```
viOpenDefaultRM(sesn);  
viOpen(sesn, rsrcName, accessMode, timeout,  
      vi);
```

The session returned from **viOpenDefaultRM** must be used in the *sesn* parameter of the **viOpen** function. The **viOpen** function then uses that session and the resource address specified in the *rsrcName* parameter to open a resource session. The *vi* parameter in **viOpen** returns a session identifier that can be used with other VISA functions.

Your program may have several sessions open at the same time after creating multiple session identifiers by calling the **viOpen** function multiple times. The following table summarizes the parameters in the previous function calls.

Table 5 Parameters Used in Function Calls

Parameter	Description
sesn	A session returned from the viOpenDefaultRM function that identifies the resource manager session.
rsrcName	A unique symbolic name of the resource (resource address).
accessMode	Specifies the modes by which the resource is to be accessed. The value VI_EXCLUSIVE_LOCK is used to acquire an exclusive lock immediately upon opening a session. If a lock cannot be acquired, the session is closed and an error is returned. The VI_LOAD_CONFIG value is used to configure attributes specified by some external configuration utility. If this value is not used, the session uses the default values provided by this specification. Multiple access modes can be used simultaneously by specifying a “bit-wise OR” of the values.
timeout	If the <i>accessMode</i> parameter requires a lock, this parameter specifies the absolute time period (in milliseconds) that the resource waits to get unlocked before this operation returns an error. Otherwise, this parameter is ignored.
vi	This is a pointer to the session identifier for this particular resource session. This pointer will be used to identify this resource session when using other VISA functions.

Sample: Opening a Resource Session

This code sample shows one way of opening resource sessions with a GPIB multimeter and a GPIB-VXI scanner. The sample first opens a session with the default resource manager. The sample then uses the session returned from the resource manager, and a VISA address, to open a session with the GPIB device at address 22. You can now identify that session as *dmm* when you call other VISA functions.

The sample again uses the session returned from the resource manager, with another VISA address, to open a session with the GPIB-VXI device at primary address 9 and VXI logical address (secondary address) 24. You will now identify this session as *scanner* when calling other VISA functions. See the following section, “Addressing a Session”, for information on addressing particular devices.

```
ViSession defaultRM, dmm, scanner;
.
viOpenDefaultRM(&defaultRM);
viOpen(defaultRM, "GPIB0::22::INSTR", VI_NULL,
        VI_NULL, &dmm);
viOpen(defaultRM, "GPIB-VXI0::24::INSTR",
        VI_NULL, VI_NULL, &scanner);
.
viClose(scanner);
viClose(dmm);
viClose(defaultRM);
```

Addressing a Session

As shown in the previous section, the *rsrcName* parameter in the **viOpen** function is used to identify a specific resource. This parameter consists of the VISA interface ID and the resource address. The interface ID is determined when you run the Agilent Connection Expert utility. The interface ID is usually the VISA interface type followed by a number.

The following table illustrates the format of the *rsrcName* for different VISA interface types. *INSTR* is an optional parameter that indicates that you are communicating with a resource that is of type INSTR, meaning instrument. The keywords are:

- **ASRL** - used for asynchronous serial devices.
- **GPIB** - used for GPIB devices and interfaces.
- **GPIB-VXI** - used for GPIB-VXI controllers.
- **TCPIP** - used for LAN instruments.
- **VXI** - used for VXI instruments.
- **USB** - used for USB instruments.

Table 6 The Format of the *rsrcName* (VISA Address) for Different Interface Types

Interface	Typical Syntax
ASRL	ASRL[<i>board</i>][:INSTR]
GPIB	GPIB[<i>board</i> :: <i>primary address</i>][: <i>secondary address</i>][:INSTR]
GPIB	GPIB[<i>board</i>]:INTFC
GPIB-VXI	GPIB-VXI[<i>board</i>]:VXI logical address[:INSTR]
GPIB-VXI	GPIB-VXI[<i>board</i>]:MEMACC
GPIB-VXI	GPIB-VXI[<i>board</i>][:VXI logical address]:BACKPLANE
TCPIP	TCPIP[<i>board</i>]:host address[:LAN device name]:INSTR
TCPIP	TCPIP[<i>board</i>]:host address::port::SOCKET
USB	USB[<i>board</i>]:manufacturer ID::model code::serial number[:USB interface number][:INSTR]
VXI	VXI[<i>board</i>]:VXI logical address[:INSTR]
VXI	VXI[<i>board</i>]:MEMACC
VXI	VXI[<i>board</i>][:VXI logical address]:BACKPLANE

The following table describes the parameters used above.

Table 7 Description of Parameters

Parameter	Description
board	This optional parameter is used if you have more than one interface of the same type. The default value for <i>board</i> is 0.
host address	The IP address (in dotted decimal notation) or the name of the host computer/gateway.

Table 7 Description of Parameters

LAN device name	The assigned name for a LAN device. Device Name depends on LAN Host Device (see documentaiton that came with your LAN Host device such as E5810A). The default is <i>inst()</i> .
manufacturer ID	Manufacturer's ID for a USB Test & Measurement class device
model code	Model code of a USB device.
port	The port number to use for a TCP/IP Socket connection.
primary address	The primary address of the GPIB device.
secondary address	This optional parameter is the secondary address of the GPIB device. If no <i>secondary address</i> is specified, none is assumed.
serial number	Serial number of a USB device.
USB interface number	Interface number of a USB device.
VXI logical address	Logical address of a VXI instrument within a mainframe.

Some examples of valid VISA addresses follow.

Table 8 Examples of Valid VISA Addresses

Address String	Description
VXI0::1::INSTR	A VXI device at logical address 1 in VXI interface VXI0.
GPIB-VXI::9::INSTR	A VXI device at logical address 9 in a GPIB-VXI controlled VXI system.
GPIB::1::0::INSTR	A GPIB device at primary address 1 and secondary address 0 in GPIB interface 0.
ASRL1::INSTR	A serial device located on port 1.
VXI::MEMACC	Board-level register access to the VXI interface.

Table 8 Examples of Valid VISA Addresses

GPIB-VXI1::MEMACC	Board-level register access to GPIB-VXI interface number 1.
GPIB2::INTFC	Interface or raw resource for GPIB interface 2.
VXI::1::BACKPLANE	Mainframe resource for chassis 1 on the default VXI system, which is interface 0.
GPIB-VXI2:: BACKPLANE	Mainframe resource for default chassis on GPIB-VXI interface 2.
GPIB1::SERVANT	Servant/device-side resource for GPIB interface 1.
VXI0::SERVANT	Servant/device-side resource for VXI interface 0.
TCPIP0::1.2.3.4::999::SOCKET	Raw TCPIP access to port 999 at the specified address.
TCPIP::devicename@company.com::INSTR	TCPIP device using VXI-11 located at the specified address. This uses the default LAN Device Name of <i>inst0</i> .
USB::0x1234::125::A22-5::INSTR	USB Test & Measurement class device with manufacturer ID 0x1234, model code 125, and serial number A22-5. This uses the device's first available USBTMC interface, which is usually numbered 0.

Sample: Opening a Session

This sample shows one way to open a VISA session with the GPIB device at primary address 23.

```
ViSession defaultRM, vi;
.
.
viOpenDefaultRM(&defaultRM);
viOpen(defaultRM, "GPIB0::23::INSTR", VI_NULL,
        VI_NULL, &vi);
.
```

3 Programming with VISA

```
.  
viClose(vi);  
viClose(defaultRM);
```

Closing a Session

You must use the **viClose** function to close each session. You can close the specific resource session, which will free all data structures that had been allocated for the session. If you close the default resource manager session, all sessions opened using that resource manager session will be closed.

Since system resources are also used when searching for resources (**viFindRsrc**), the **viClose** function needs to be called to free up find lists. See the following section, “Searching for Resources”, for more information on closing find lists.

Searching for Resources

When you open the default resource manager, you are opening a parent session that knows about all the other resources in the system. Since the resource manager session knows about all resources, it has the ability to search for specific resources and open sessions to these resources. You can, for example, search an interface for devices and open a session with one of the devices found.

Use the **viFindRsrc** function to search an interface for device resources. This function finds matches and returns the number of matches found and a handle to the resources found. If there are more matches, use the **viFindNext** function with the handle returned from **viFindRsrc** to get the next match:

```
viFindRsrc(sesn, expr, findList, retcnt,
          instrDesc);
.
.
viFindNext(findList, instrDesc);
.
.
viClose (findList);
```

The parameters are defined as follows.

Table 9 Definitions of Parameters

Parameter	Description
sesn	The resource manager session.
expr	The expression that identifies what to search (see Table 10).
findList	A handle that identifies this search. This handle will then be used as an input to the viFindNext function when finding the next match.
retcnt	A pointer to the number of matches found.
instrDesc	A pointer to a string identifying the location of the match. Note that you must allocate storage for this string.

The handle returned from **viFindRsrc** should be closed to free up all the system resources associated with the search. To close the find object, pass the *findList* to the **viClose** function.

Use the *expr* parameter of the **viFindRsrc** function to specify the interface to search. You can search for devices on the specified interface. Use the following table to determine what to use for your *expr* parameter.

NOTE

Because VISA interprets strings as regular expressions, the string *GPIB?*INSTR* applies to *both* GPIB and GPIB-VXI devices.

Table 10 Determining What to Use for the *expr* Parameter

Interface	<i>expr</i> Parameter
GPIB	GPIB[0-9]*::?*INSTR
VXI	VXI?*INSTR
GPIB-VXI	GPIB-VXI?*INSTR
GPIB and GPIB-VXI	GPIB?*INSTR

Table 10 Determining What to Use for the *expr* Parameter

All VXI	?*VXI[0-9]*::~?*INSTR
ASRL	ASRL[0-9]*::~?*INSTR
All	?*INSTR

Sample: Searching the VXI Interface for Resources

This code sample searches the VXI interface for resources. The number of matches found is returned in *nmatches*, and *matches* points to the string that contains the matches found. The first call returns the first match found, the second call returns the second match found, etc. VI_FIND_BUFLen is defined in the `visa.h` declarations file.

```
ViChar buffer [VI_FIND_BUFLen];
ViRsrc matches=buffer;
ViUInt32 nmatches;
ViFindList list;
.
.
viFindRsrc(defaultRM, "VXI?*INSTR", &list,
           &nmatches, matches);
..
.
viFindNext(list, matches);
.
.
viClose(list);
```

Sending I/O Commands

This section provides guidelines for sending I/O commands, including:

- Types of I/O
- Using Formatted I/O
- Using Non-Formatted I/O

Types of I/O

Once you have established a communications session with a device, you can start communicating with that device using VISA's I/O routines. VISA provides both formatted and non-formatted I/O routines.

- **Formatted I/O** converts mixed types of data under the control of a format string. The data is buffered, thus optimizing interface traffic.
- **Non-formatted I/O** sends or receives raw data to or from a device. With non-formatted I/O, no format or conversion of the data is performed. Thus, if formatted data is required, it must be done by the user.

You can choose between VISA's formatted and non-formatted I/O routines. However, you should not mix formatted I/O and non-formatted I/O in the same session. See the following sections for descriptions and code samples using formatted I/O and non-formatted I/O in VISA.

Using Formatted I/O

The VISA formatted I/O mechanism is similar to the C `stdio` mechanism. The VISA formatted I/O functions are **viPrintf**, **viQueryf**, and **viScanf**. There are also two non-buffered and non-formatted I/O functions that synchronously transfer data, called **viRead** and **viWrite**, and two that asynchronously transfer data, called **viReadAsync** and **viWriteAsync**.

These are raw I/O functions and do not intermix with the formatted I/O functions. See “Using Non-Formatted I/O” in this chapter for details. See the *VISA Online Help* for more information on how data is converted under the control of the format string.

Formatted I/O Functions

As noted, the VISA formatted I/O functions are **viPrintf**, **viQueryf**, and **viScanf**.

- The **viPrintf** functions format according to the format string and send data to a device. The **viPrintf** function sends separate *arg* parameters, while the **viVPrintf** function sends a list of parameters in *params*:

```
viPrintf(vi, writeFmt[, arg1][, arg2][, ...]);
viVPrintf(vi, writeFmt, params);
```

- The **viScanf** functions receive and convert data according to the format string. The **viScanf** function receives separate *arg* parameters, while the **viVScanf** function receives a list of parameters in *params*:

```
viScanf(vi, readFmt[, arg1][, arg2][, ...]);
viVScanf(vi, readFmt, params);
```

- The **viQueryf** functions format and send data to a device and then immediately receive and convert the response data. Hence, the **viQueryf** function is a combination of the **viPrintf** and **viScanf** functions. Similarly, the **viVQueryf** function is a combination of the **viVPrintf** and **viVScanf** functions. The **viQueryf** function sends and receives separate *arg* parameters, while the **viVQueryf** function sends and receives a list of parameters in *params*:

```
viQueryf(vi, writeFmt, readFmt[, arg1]
[, arg2][, ...]);
viVQueryf(vi, writeFmt, readFmt, params);
```

Formatted I/O Conversion

The formatted I/O functions convert data under the control of the format string. The format string specifies how the argument is converted before it is input or output. The format specifier sequence consists of a % (percent) followed by an optional modifier(s), followed by a format code.

```
%[modifiers]format code
```

(See Table 11, “Descriptions of Format Codes,” on page 45.) Zero or more modifiers may be used to change the meaning of the format code. Modifiers are only used when sending or receiving formatted I/O. To send formatted I/O, the asterisk (*) can be used to indicate that the number is taken from the next argument.

However, when the asterisk is used when receiving formatted I/O, it indicates that the assignment is suppressed and the parameter is discarded. Use the pound sign (#) when receiving formatted I/O to indicate that an extra argument is used. The following are supported modifiers. See the **viPrintf** function in the *VISA Online Help* for additional enhanced modifiers (**@1**, **@2**, **@3**, **@H**, **@Q**, or **@B**).

Field Width Field width is an optional integer that specifies how many characters are in the field. If the **viPrintf** or **viQueryf** (*writeFmt*) formatted data has fewer characters than specified in the field width, it will be padded on the left, or on the right if the **-flag** is present.

You can use an asterisk (*) in place of the integer in **viPrintf** or **viQueryf** (*writeFmt*) to indicate that the integer is taken from the next argument. For the **viScanf** or **viQueryf** (*readFmt*) functions, you can use a # sign to indicate that the next argument is a reference to the field width.

The field width modifier is only supported with **viPrintf** and **viQueryf** (*writeFmt*) format codes **d**, **f**, **s**, and **viScanf** and **viQueryf** (*readFmt*) format codes **c**, **s**, and **[]**. (See Table 11 for a description of format codes.)

Sample: Using Field Width Modifier

The following sample pads **numb** to six characters and sends it to the session specified by *vi*:

```
int numb = 61;
viPrintf(vi, "%6d\n", numb);
```

Inserts four spaces, for a total of 6 characters: **61**

.Precision Precision is an optional integer preceded by a period. This modifier is only used with the **viPrintf** and **viQueryf** (*writeFmt*) functions. The meaning of this argument is dependent on the conversion character used. You can use an asterisk (*) in place of the integer to indicate the integer is taken from the next argument.

Table 11 Descriptions of Format Codes

Format Code	Description
d	Indicates the minimum number of digits to appear is specified for the @1 , @H , @Q , and @B flags, and the i , o , u , x , and X format codes.
f	Indicates the maximum number of digits after the decimal point is specified.
s	Indicates the maximum number of characters for the string is specified.
g	Indicates the maximum significant digits are specified.

Sample: Using the Precision Modifier

This sample converts **numb** so that there are only two digits to the right of the decimal point and sends it to the session specified by *vi*:

```
float numb = 26.9345;
viPrintf(vi, "%.2f\n", numb);
```

Sends: **26.93**

Argument Length Modifier The meaning of the optional argument length modifier **h**, **l**, **L**, **z**, or **Z** is dependent on the conversion character, as listed in the following table. Note that **z** and **Z** are not ANSI C standard modifiers.

Table 12 Argument Length Modifiers

Argument Length Modifier	Format Codes	Description
h	d,b,B	Corresponding argument is a short integer or a reference to a short integer for d . For b or B , the argument is the location of a block of data or a reference to a data array. (B is only used with viPrintf or viQueryf (<i>writeFmt</i>).)
l	d,f,b,B	Corresponding argument is a long integer or a reference to a long integer for d . For f , the argument is a double float or a reference to a double float. For b or B , the argument is the location of a block of data or a reference to a data array. (B is only used with viPrintf or viQueryf (<i>writeFmt</i>).)
L	f	Corresponding argument is a long double or a reference to a long double.
z	b,B	Corresponding argument is an array of floats or a reference to an array of floats. (B is only used with viPrintf or viQueryf (<i>writeFmt</i>).)
Z	b,B	Corresponding argument is an array of double floats or a reference to an array of double floats. (B is only used with viPrintf or viQueryf (<i>writeFmt</i>).)

, Array Size The comma operator is a format modifier that allows you to read or write a comma-separated list of numbers (only valid with **%d** and **%f** format codes). It is a comma followed by an integer. The integer indicates the number of elements in the array. The comma operator has the format of *,dd* where *dd* is the number of elements to read or write.

For **viPrintf** or **viQueryf** (*writeFmt*), you can use an asterisk (*) in place of the integer to indicate that the integer is taken from the next argument. For **viScanf** or **viQueryf** (*readFmt*), you can use a # sign to indicate that the next argument is a reference to the array size.

Sample: Using Array Size Modifier

This sample specifies a comma-separated list to be sent to the session specified by *vi*:

```
int list[5]={101,102,103,104,105};
viPrintf(vi, "%,5d\n", list);
```

Sends: **101,102,103,104,105**

Special Characters Special formatting character sequences will send special characters. The following describes the special characters and what will be sent.

The format string for **viPrintf** and **viQueryf** (*writeFmt*) puts a special meaning on the newline character (*\n*). The newline character in the format string flushes the output buffer to the device.

All characters in the output buffer will be written to the device with an **END** indicator included with the last byte (the newline character). This means you can control at what point you want the data written to the device. If no newline character is included in the format string, the characters converted are stored in the output buffer. It will require another call to **viPrintf**, **viQueryf** (*writeFmt*), or **viFlush** to have those characters written to the device.

This can be very useful in queuing up data to send to a device. It can also raise I/O performance by doing a few large writes instead of several smaller writes. The * while using the **viScanf** functions acts as an assignment suppression character. The input is not assigned to any parameters and is discarded.

The grouping operator () in a regular expression has the highest precedence, the + and * operators in a regular expression have the next highest precedence after the grouping operator, and the *or* operator | in a regular expression has the lowest precedence. The following table provides detailed descriptions of special characters and operators. Some example expressions follow in Table 14

Table 13 Descriptions of Special Characters and Operators

Special Characters and Operators	Description
?	Matches any one character.
\	Makes the character that follows it an ordinary character instead of special character. For example, when a question mark follows a backslash (e.g., '\?'), it matches the '?' character instead of any one character.
[<i>list</i>]	Matches any one character from the enclosed <i>list</i> . A hyphen can be used to match a range of characters.
[^ <i>list</i>]	Matches any character not in the enclosed <i>list</i> . A hyphen can be used to match a range of characters.
*	Matches 0 or more occurrences of the preceding character or expression.
+	Matches 1 or more occurrences of the preceding character or expression.
<i>exp exp</i>	Matches either the preceding or following expression. The <i>or</i> operator matches the entire expression that precedes or follows it and not just the character that precedes or follows it. For example, VXI GPIB means (VXI) (GPIB) , not VXI(I G)PIB .
(<i>exp</i>)	Grouping characters or expressions.
“ “	Sends a blank space.
\n	Sends the ASCII line feed character. The END identifier will also be sent.
\r	Sends an ASCII carriage return character.
\t	Sends an ASCII TAB character.
\###	Sends ASCII character specified by octal value.
\"	Sends the ASCII double quote character.
\\	Sends a backslash character.

Table 14 Examples of Expressions and Matches

Example Expression	Sample Matches
GPIB?*INSTR	Matches GPIB0::2::INSTR , GPIB1::1::1::INSTR , and GPIB-VXI1::8::INSTR
GPIB[0-9]*::*INSTR	Matches GPIB0::2::INSTR and GPIB1::1::1::INSTR but not GPIB-VXI1::8::INSTR
GPIB[0-9]:::*INSTR	Matches GPIB0::2::INSTR and GPIB1::1::1::INSTR but not GPIB12::8::INSTR
GPIB[^0]:::*INSTR	Matches GPIB1::1::1::INSTR but not GPIB0::2::INSTR or GPIB12::8::INSTR
VXI?*INSTR	Matches VXI0::1::INSTR but not GPIB-VXI0::1::INSTR
GPIB-VXI?*INSTR	Matches GPIB-VXI0::1::INSTR but not VXI0::1::INSTR
?*VXI[0-9]*::*INSTR	Matches VXI0::1::INSTR and GPIB-VXI0::1::INSTR
ASRL[0-9]*::*INSTR	Matches ASRL1::INSTR but not VXI0::5::INSTR
ASRL1+::INSTR	Matches ASRL1::INSTR and ASRL11::INSTR but not ASRL2::INSTR
(GPIB VXI)?*INSTR	Matches GPIB1::5::INSTR and VXI0::3::INSTR but not ASRL2::INSTR
(GPIB0 VXI0)::1::INSTR	Matches GPIB0::1::INSTR and VXI0::1::INSTR
?*INSTR	Matches all INSTR (device) resources
?*VXI[0-9]*::*MEMACC	Matches VXI0::MEMACC and GPIB-VXI1::MEMACC
VXI0::?*	Matches VXI0::1::INSTR , VXI0::2::INSTR , and VXI0::MEMACC
?*	Matches all resources

Format Codes. This table summarizes the format codes for sending and receiving formatted I/O.

Table 15 Format Codes for Sending and Receiving Formatted I/O

Format Codes	Description
viPrintf/viVPrintf and viQueryf/viVqueryf (<i>writeFmt</i>)	
d, i	Corresponding argument is an integer.
f	Corresponding argument is a double.
c	Corresponding argument is a character.
s	Corresponding argument is a pointer to a null terminated string.
%	Sends an ASCII percent (%) character.
o, u, x, X	Corresponding argument is an unsigned integer.
e, E, g, G	Corresponding argument is a double.
n	Corresponding argument is a pointer to an integer.
b, B	Corresponding argument is the location of a block of data.
viPrintf/viVPrintf and viQueryf/viVqueryf (<i>readFmt</i>)	
d,i,n	Corresponding argument must be a pointer to an integer.
e,f,g	Corresponding argument must be a pointer to a float.
c	Corresponding argument is a pointer to a character sequence.
s,t,T	Corresponding argument is a pointer to a string.
o,u,x	Corresponding argument must be a pointer to an unsigned integer.
[Corresponding argument must be a character pointer.
b	Corresponding argument is a pointer to a data array.

Sample: Receiving Data From a Session

This sample receives data from the session specified by the *vi* parameter and converts the data to a string.

```
char data[180];
viScanf(vi, "%t", data);
```

Formatted I/O Buffers

The VISA software maintains both a read and write buffer for formatted I/O operations. Occasionally, you may want to control the actions of these buffers. You can modify the size of the buffer using the **viSetBuf** function. See the *VISA Online Help* for more information on this function.

The write buffer is maintained by the **viPrintf** or **viQueryf** (*writeFmt*) functions. The buffer queues characters to send to the device so that they are sent in large blocks, thus increasing performance. The write buffer automatically flushes when it sends a newline character from the format string. It may occasionally be flushed at other non-deterministic times, such as when the buffer fills.

When the write buffer flushes, it sends its contents to the device. If you set the VI_ATTR_WR_BUF_OPER_MODE attribute to VI_FLUSH_ON_ACCESS, the write buffer will also be flushed every time a **viPrintf** or **viQueryf** operation completes. See “VISA Attributes” in this chapter for information on setting VISA attributes.

The read buffer is maintained by the **viScanf** and **viQueryf** (*readFmt*) functions. It queues the data received from a device until it is needed by the format string. Flushing the read buffer destroys the data in the buffer and guarantees that the next call to **viScanf** or **viQueryf** reads data directly from the device rather than data that was previously queued.

If you set the VI_ATTR_RD_BUF_OPER_MODE attribute to VI_FLUSH_ON_ACCESS, the read buffer will be flushed every time a **viScanf** or **viQueryf** operation completes. See “VISA Attributes” in this chapter for information on setting VISA attributes.

You can manually flush the read and write buffers using the **viFlush** function. Flushing the read buffer also includes reading all pending response data from a device. If the device is still sending data, the flush process will continue to read data from the device until it receives an **END** indicator from the device.

Sample: Sending and Receiving Formatted I/O

This C sample program shows sending and receiving formatted I/O. The sample opens a session with a GPIB device and sends a comma operator to send a comma-separated list. This sample program is intended to show specific VISA functionality and does not include error trapping. Error trapping, however, is good programming practice and is recommended in your VISA applications. See “Trapping Errors” in this chapter for more information.

This sample program is installed on your system in the `ProgrammingSamples` subdirectory. See the *IO Libraries Suite Online Help* for locations of sample programs on your operating system.

```
/*formatio.c
This example program makes a multimeter
measurement with a comma-separated list passed
with formatted I/O and prints the results. You
may need to change the device address. */

#include <visa.h>
#include <stdio.h>

void main () {

    ViSession defaultRM, vi;
    double res;
    double list [2] = {1,0.001};

    /* Open session to GPIB device at address 22*/
    viOpenDefaultRM(&defaultRM);
    viOpen(defaultRM, "GPIB0::22::INSTR",
           VI_NULL,VI_NULL, &vi);

    /* Initialize device */
    viPrintf(vi, "*RST\n");
```

```

/* Set up device and send a comma-separated
list */
viPrintf(vi, "CALC:DBM:REF 50\n");
viPrintf(vi, "MEAS:VOLT:AC? %,2f\n", list);

/* Read results */
viScanf(vi, "%lf", &res);

/* Print results */
printf("Measurement Results: %lf\n", res);

/* Close session */
viClose(vi);
viClose(defaultRM);
}

```

Using Non-Formatted I/O

There are two non-buffered, non-formatted I/O functions that synchronously transfer data called **viRead** and **viWrite**. Also, there are two non-formatted I/O functions that asynchronously transfer data called **viReadAsync** and **viWriteAsync**. These are raw I/O functions and do not intermix with the formatted I/O functions.

Non-Formatted I/O Functions

The non-formatted I/O functions follow. For more information, see the **viRead**, **viWrite**, **viReadAsync**, **viWriteAsync**, and **viTerminate** functions in the *VISA Online Help*.

viRead. The **viRead** function synchronously reads raw data from the session specified by the *vi* parameter and stores the results in the location where *buf* is pointing. Only one synchronous read operation can occur at any one time.

```
viRead(vi, buf, count, retCount);
```

viWrite. The **viWrite** function synchronously sends the data pointed to by *buf* to the device specified by *vi*. Only one synchronous write operation can occur at any one time.

```
viWrite(vi, buf, count, retCount);
```

viReadAsync. The **viReadAsync** function asynchronously reads raw data from the session specified by the *vi* parameter and stores the results in the location where *buf* is pointing. This operation normally returns before the transfer terminates. Thus, the operation returns *jobId*, which you can use with either **viTerminate** to abort the operation or with an I/O completion event to identify which asynchronous read operation completed.

```
viReadAsync(vi, buf, count, jobId);
```

viWriteAsync. The **viWriteAsync** function asynchronously sends the data pointed to by *buf* to the device specified by *vi*. This operation normally returns before the transfer terminates. Thus, the operation returns *jobId*, which you can use with either **viTerminate** to abort the operation or with an I/O completion event to identify which asynchronous write operation completed.

```
viWriteAsync(vi, buf, count, jobId);
```

Sample: Using Non-Formatted I/O Functions

This sample program illustrates using non-formatted I/O functions to communicate with a GPIB device. This sample program is intended to show specific VISA functionality and does not include error trapping. Error trapping, however, is good programming practice and is recommended in your VISA applications. See “Trapping Errors” in this chapter for more information.

```
/*nonfmtio.c
This example program measures the AC voltage on
a multimeter and prints the results. You may
need to change the device address. */

#include <visa.h>
#include <stdio.h>

void main () {

    ViSession defaultRM, vi;
    char strres [20];
    unsigned long actual;
```

```
/* Open session to GPIB device at address 22 */
viOpenDefaultRM(&defaultRM);
viOpen(defaultRM, "GPIB0::22::INSTR",
        VI_NULL,VI_NULL, &vi);

/* Initialize device */
viWrite(vi, (ViBuf)"*RST\n", 5, &actual);

/* Set up device and take measurement */
viWrite(vi, (ViBuf)"CALC:DBM:REF 50\n", 16,
        &actual);
viWrite(vi, (ViBuf)"MEAS:VOLT:AC? 1, 0.001\n",
        23, &actual);

/* Read results */
viRead(vi, (ViBuf)strres, 20, &actual);

/* NULL terminate the string */
strres[actual]=0;

/* Print results */
printf("Measurement Results: %s\n", strres);

/* Close session */
viClose(vi);
viClose(defaultRM);
}
```

Using Events and Handlers

This section provides guidelines to using events and handlers, including:

- Events and Attributes
- Using the Callback Method
- Using the Queuing Method

Events and Attributes

Events are special occurrences that require attention from your application. Event types include Service Requests (SRQs), interrupts, and hardware triggers. Events will not be delivered unless the appropriate events are enabled.

NOTE

VISA cannot call back to a Visual Basic function. Thus, you can only use the **queuing** mechanism in **viEnableEvent**. There is no way to install a VISA event handler in Visual Basic.

Event Notification

There are two ways you can receive notification that an event has occurred:

- Install an event handler with **viInstallHandler**, and enable one or several events with **viEnableEvent**. If the event was enabled with a handler, the specified event handler will be called when the specified event occurs. This is called a **callback**.

NOTE

VISA cannot call back to a Visual Basic function. This means that you can only use the **VI_QUEUE** mechanism in **viEnableEvent**. There is no way to install a VISA event handler in Visual Basic.

- Enable one or several events with **viEnableEvent** and call the **viWaitOnEvent** function. The **viWaitOnEvent** function will suspend the program execution until the specified event occurs or the specified timeout period is reached. This is called **queuing**.

The queuing and callback mechanisms are suitable for different programming styles. The queuing mechanism is generally useful for non-critical events that do not need immediate servicing. The callback mechanism is useful when immediate responses are needed. These mechanisms work independently of each other, so both can be enabled at the same time. By default, a session is not enabled to receive any events by either mechanism.

The **viEnableEvent** operation can be used to enable a session to respond to a specified event type using either the queuing mechanism, the callback mechanism, or both. Similarly, the **viDisableEvent** operation can be used to disable one or both mechanisms. Because the two methods work independently of each other, one can be enabled or disabled regardless of the current state of the other.

Events that can be Enabled

The following table shows the events that are implemented for Agilent VISA for each resource class, where AP = Access Privilege, RO - Read Only, and RW = Read/Write. Note that some resource classes/events, such as the **SERVANT** class, are not implemented by Agilent VISA and are not listed in the following tables.

Once the application has received an event, information about that event can be obtained by using the **viGetAttribute** function on that particular event context. Use the VISA **viReadSTB** function to read the status byte of the service request.

Table 16 Instrument Control (INSTR) Resource Events

VI_EVENT_SERVICE_REQUEST				
Notification that a service request was received from the device.				
Event Attribute	Description	A P	Data Type	Range
VI_ATTR_EVENT_TYPE	Unique logical identifier of the event.	R O	ViEventTy pe	VI_EVENT_SERVICE_RE Q
VI_EVENT_VXI_SIGP				
Notification that a VXIbus signal or VXIbus interrupt was received from the device.				

3 Programming with VISA

Table 16 Instrument Control (INSTR) Resource Events

Event Attribute	Description	A P	Data Type	Range
VI_ATTR_EVENT_TYPE	Unique logical identifier of the event.	R O	ViEventType	VI_EVENT_VXI_STOP
VI_ATTR_SIGP_STATUS_ID	The 16-bit Status/ID value retrieved during the IACK cycle or from the Signal register.	R O	ViUInt16	0 to FFFF _h

VI_EVENT_TRIG

Notification that a trigger interrupt was received from the device. For VISA, the only triggers that can be sensed are VXI hardware triggers on the assertion edge (SYNC and ON trigger protocols only).

Event Attribute	Description	A P	Data Type	Range
VI_ATTR_EVENT_TYPE	Unique logical identifier of the event.	R O	ViEventType	VI_EVENT_TRIG
VI_ATTR_RECV_TRIG_ID	The identifier of the triggering mechanism on which the specified trigger event was received.	R O	ViInt16	VI_TRIG_TTL0 to VI_TRIG_TTL7; VI_TRIG_ECL0 to VI_TRIG_ECL1*

* Agilent VISA can also return VI_TRIG_PANEL_IN (exception to the VISA Specification)

VI_EVENT_IO_COMPLETION

Notification that an asynchronous operation has completed.

Event Attribute	Description	A P	Data Type	Range
VI_ATTR_EVENT_TYPE	Unique logical identifier of the event.	R O	ViEventType	VI_EVENT_IO_COMPLETION
VI_ATTR_STATUS	Return code of the asynchronous I/O operation that has completed.	R O	ViStatus	N/A
VI_ATTR_JOB_ID	Job ID of the asynchronous operation that has completed.	R O	ViJobId	N/A
VI_ATTR_BUFFER	Address of a buffer that was used in an asynchronous operation.	R O	ViBuf	N/A

Table 16 Instrument Control (INSTR) Resource Events

VI_ATTR_RET_COUNT	Actual number of elements that were asynchronously transferred.	R O	ViUInt32	0 to FFFFFFFF _h
VI_ATTR_OPER_NAME	Name of the operation generating the event.		ViString	N/A
VI_EVENT_USB_INTR				
Notification that a vendor-specific USB interrupt was received from the device.				
Event Attribute	Description	A P	Data Type	Range
VI_ATTR_EVENT_TYPE	Unique logical identifier of the event.	R O	ViEventType	VI_EVENT_USB_INTR
VI_ATTR_USB_RECV_INTR_SIZE	Specifies the size of the data that was received from the USB interrupt-IN pipe. This value will never be larger than the sessions value of VI_ATTR_USB_MAX_INTR_SIZE.	R O	ViUInt16	0 to FFFFh
VI_ATTR_USB_RECV_INTR_DATA	Specifies the actual data that was received from the USB interrupt-IN pipe. Querying this attribute copies the contents of the data to the users buffer. The users buffer must be sufficiently large enough to hold all of the data.	R O	ViBuf	N/A
VI_ATTR_STATUS	Specifies the status of the read operation from the USB interrupt-IN pipe. If the device sent more data than the user specified in VI_ATTR_USB_MAX_INTR_SIZE, then this attribute value will contain an error code.	R O	ViStatus	N/A

3 Programming with VISA

Table 17 Memory Access (MEMACC) Resource Event

VI_EVENT_IO_COMPLETION				
Notification that an asynchronous operation has completed				
Event Attribute	Description	A P	Data Type	Range
VI_ATTR_EVENT_TYPE	Unique logical identifier of the event.	R O	ViEventType	VI_EVENT_IO_COMPLETION
VI_ATTR_STATUS	Return code of the asynchronous I/O operation that has completed.	R O	ViStatus	N/A
VI_ATTR_JOB_ID	Job ID of the asynchronous operation that has completed.	R O	ViJobId	N/A
VI_ATTR_BUFFER	Address of a buffer that was used in an asynchronous operation.	R O	ViBuf	N/A
VI_ATTR_RET_COUNT	Actual number of elements that were asynchronously transferred.	R O	ViUInt32	0 to FFFFFFFF _h
VI_ATTR_OPER_NAME	Name of the operation generating the event.	R O	ViString	N/A

Table 18 GPIB Bus Interface (INTFC) Resource Events

VI_EVENT_GPIB_CIC				
Notification that the GPIB controller has gained or lost CIC (controller in charge) status				
Event Attribute	Description	A P	Data Type	Range
VI_ATTR_EVENT_TYPE	Unique logical identifier of the event.	R O	ViEventType	VI_EVENT_GPIB_CIC
VI_ATTR_GPIB_RECV_CIC_STATE	Controller has become controller-in-charge.	R O	ViBoolean	VI_TRUE VI_FALSE

VI_EVENT_GPIB_TALK

Notification that the GPIB controller has been addressed to talk

Table 18 GPIB Bus Interface (INTFC) Resource Events

Event Attribute	Description	AP	Data Type	Range
VI_ATTR_EVENT_TYPE	Unique logical identifier of the event.	RO	ViEventTy pe	VI_EVENT_GPIB_TAL K
VI_EVENT_GPIB_LISTEN				
Notification that the GPIB controller has been addressed to listen.				
Event Attribute	Description	AP	Data Type	Range
VI_ATTR_EVENT_TYPE	Unique logical identifier of the event.	RO	ViEventTy pe	VI_EVENT_GPIB_LIST EN
VI_EVENT_CLEAR				
Notification that the GPIB controller has been sent a device clear message.				
Event Attribute	Description	AP	Data Type	Range
VI_ATTR_EVENT_TYPE	Unique logical identifier of the event.	RO	ViEventTy pe	VI_EVENT_CLEAR
VI_EVENT_TRIGGER				
Notification that a trigger interrupt was received from the interface.				
Event Attribute	Description	AP	Data Type	Range
VI_ATTR_EVENT_TYPE	Unique logical identifier of the event.	RO	ViEventTy pe	VI_EVENT_TRIG
VI_ATTR_RECV_TRIG_ID	The identifier of the triggering mechanism on which the specified trigger event was received.	RO	ViInt16	VI_TRIG_SW
VI_EVENT_IO_COMPLETION				
Notification that an asynchronous operation has completed.				

3 Programming with VISA

Table 18 GPIB Bus Interface (INTFC) Resource Events

Event Attribute	Description	A P	Data Type	Range
VI_ATTR_EVENT_TYPE	Unique logical identifier of the event.	R O	ViEventTy pe	VI_EVENT_IO_ COMPLETION
VI_ATTR_STATUS	Return code of the asynchronous I/O operation that has completed.	R O	ViStatus	N/A
VI_ATTR_JOB_ID	Job ID of the asynchronous operation that has completed.	R O	ViJobId	N/A
VI_ATTR_BUFFER	Address of buffer used in an asynchronous operation.	R O	ViBuf	N/A
VI_ATTR_RET_COUNT	Actual number of elements that were asynchronously transferred.	R O	ViUInt32	0 to FFFFFFFF _h
VI_ATTR_OPER_NAME	The name of the operation generating the event.	R O	ViString	N/A

Table 19 VXI Mainframe Backplane (BACKPLANE) Resource Events

VI_EVENT_TRIG				
Notification that a trigger interrupt was received from the backplane. For VISA, the only triggers that can be sensed are VXI hardware triggers on the assertion edge (SYNC and ON trigger protocols only).				
Event Attribute	Description	A P	Data Type	Range
VI_ATTR_EVENT_TYPE	Unique logical identifier of the event.	R O	ViEventTy pe	VI_EVENT_TRIG
VI_ATTR_RECV_TRIG_ID	The identifier of the triggering mechanism on which the specified trigger event was received.	R O	ViInt16	VI_TRIG_TTL0 to VI_TRIG_TTL7; VI_TRIG_ECL0 to VI_TRIG_ECL1
VI_EVENT_VXI_VME_SYSFAIL				
Notification that the VXI/VME SYSFAIL* line has been asserted.				

Table 19 VXI Mainframe Backplane (BACKPLANE) Resource Events

Event Attribute	Description	Access	Data Type	Range
VI_ATTR_EVENT_TYPE	Unique logical identifier of the event.	RO	ViEventTy pe	VI_EVENT_VXI_VME_ SYSFAIL
VI_EVENT_VXI_VME_SYSRESET				
Notification that the VXI/VME SYSRESET* line has been reset				
Event Attribute	Description	Access	Data Type	Range
VI_ATTR_EVENT_TYPE	Unique logical identifier of the event.	RO	ViEventTy pe	VI_EVENT_VXI_VME_ SYSRESET

Table 20 TCPIP Socket (SOCKET) Resource Event

VI_EVENT_IO_COMPLETION				
Notification that an asynchronous operation has completed				
Event Attribute	Description	Access	Data Type	Range
VI_ATTR_EVENT_TYPE	Unique logical identifier of the event.	RO	ViEventTy pe	VI_EVENT_IO_COMPLE TION
VI_ATTR_STATUS	Return code of the asynchronous I/O operation that has completed.	RO	ViStatus	N/A
VI_ATTR_JOB_ID	Job ID of the asynchronous operation that has completed.	RO	ViJobId	N/A
VI_ATTR_BUFFER	Address of a buffer that was used in an asynchronous operation.	RO	ViBuf	N/A
VI_ATTR_RET_COUNT	Actual number of elements that were asynchronously transferred.	RO	ViUInt32	0 to FFFFFFFF _h
VI_ATTR_OPER_NAME	Name of the operation generating the event.	RO	ViString	N/A

Sample: Reading Event Attributes

Once you have decided which attribute to check, you can read the attribute using the **viGetAttribute** function. The following sample shows one way you could check which trigger line fired when the `VI_EVENT_TRIG` event was delivered.

Note that the *context* parameter is either the event *context* passed to your event handler, or the *outcontext* specified when doing a wait on event. See “VISA Attributes” in this chapter for more information on reading attribute states.

```
ViInt16 state;
.
.
viGetAttribute(context, VI_ATTR_RECV_TRIG_ID,
               &state)
```

Using the Callback Method

The callback method of event notification is used when an immediate response to an event is required. To use the callback method for receiving notification that an event has occurred, you must do the following.

- Install an event handler with the **viInstallHandler** function
- Enable one or several events with the **viEnableEvent** function

When the enabled event occurs, the installed event handler is called.

Sample: Using the Callback Method

This sample shows one way you can use the callback method.

```
ViStatus _VI_FUNCH my_handler (ViSession vi,
                               ViEventType eventType, ViEvent context, ViAddr
                               usrHandle) {

    /* your event handling code here */

    return VI_SUCCESS;

}

main() {
    ViSession vi;
```



```

ViAddr addr=0;
.
.
viInstallHandler(vi, VI_EVENT_SERVICE_REQ,
    my_handler, addr);
viEnableEvent(vi, VI_EVENT_SERVICE_REQ,
    VI_HNDLR, VI_NULL);
.
/* your code here */
.
viDisableEvent(vi, VI_EVENT_SERVICE_REQ,
    VI_HNDLR);
viUninstallHandler(vi, VI_EVENT_SERVICE_REQ,
    my_handler, addr);
.
}

```

Installing Handlers

VISA allows applications to install multiple handlers for an event type on the same session. Multiple handlers can be installed through multiple invocations of the **viInstallHandler** operation, where each invocation adds to the previous list of handlers.

If more than one handler is installed for an event type, each of the handlers is invoked on every occurrence of the specified event(s). VISA specifies that the handlers are invoked in Last In First Out (LIFO) order. Use the following function when installing an event handler:

```

viInstallHandler(vi, eventType, handler,
    userHandle);

```

These parameters are defined as follows.

Table 21 Parameters Used to Install a Handler

Parameter	Description
vi	The session on which the handler will be installed.
eventType	The event type that will activate the handler.
handler	The name of the handler to be called.

Table 21 Parameters Used to Install a Handler

<code>userHandle</code>	A user value that uniquely identifies the handler for the specified event type.
-------------------------	---

The *userHandle* parameter allows you to assign a value to be used with the *handler* on the specified session. Thus, you can install the same handler for the same event type on several sessions with different *userHandle* values. The same handler is called for the specified event type.

However, the value passed to *userHandle* is different. Therefore the handlers are uniquely identified by the combination of the *handler* and the *userHandle*. This may be useful when you need a different handling method depending on the *userHandle*.

Sample: Installing an Event Handler

This sample shows how to install an event handler to call *my_handler* when a Service Request occurs. Note that `VI_EVENT_SERVICE_REQ` must also be an enabled event with the **viEnableEvent** function for the service request event to be delivered.

```
viInstallHandler(vi, VI_EVENT_SERVICE_REQ,  
                my_handler, addr);
```

Use the **viUninstallHandler** function to uninstall a specific handler, or you can use wildcards (`VI_ANY_HNDLR` in the *handler* parameter) to uninstall groups of handlers. See **viUninstallHandler** in the *VISA Online Help* for more details on this function.

Writing the Handler

The *handler* installed needs to be written by the programmer. The event handler typically reads an associated attribute and performs some sort of action. See the event handler in the sample program later in this section.

Enabling Events

Before an event can be delivered, it must be enabled using the **viEnableEvent** function. This function causes the application to be notified when the enabled event has occurred, where the parameters are:

```
viEnableEvent(vi, eventType, mechanism,
             context);
```

Using VI_QUEUE in the *mechanism* parameter specifies a queuing method for the events to be handled. If you use both VI_QUEUE and one of the mechanisms listed above, notification of events will be sent to both locations. See the next subsection for information on the queuing method.

Table 22 Description of Parameters Used to Install a Handler

Parameter	Description
vi	The session on which the handler will be installed.
eventType	The type of event to enable.
mechanism	The mechanism by which the event will be enabled. It can be enabled in several different ways. You can use VI_HNDLR in this parameter to specify that the installed handler will be called when the event occurs. Use VI_SUSPEND_HNDLR in this parameter, which puts the events in a queue and waits to call the installed handlers until viEnableEvent is called with VI_HNDLR specified in the mechanism parameter. When viEnableEvent is called with VI_HNDLR specified, the handler for each queued event will be called.
context	Not used in VISA 1.0. Use VI_NULL.

Sample: Enabling a Hardware Trigger Event

This sample illustrates enabling a hardware trigger event.

```
viInstallHandler(vi, VI_EVENT_TRIG,
                my_handler, &addr);
viEnableEvent(vi, VI_EVENT_TRIG, VI_HNDLR,
              VI_NULL);
```

The VI_HNDLR mechanism specifies that the handler installed for VI_EVENT_TRIG will be called when a hardware trigger occurs.

If you specify VI_ALL_ENABLE_EVENTS in the *eventType* parameter, all events that have previously been enabled on the specified session will be enabled for the *mechanism* specified in this function call.

Use the **viDisableEvent** function to stop servicing the event specified.

Sample: Trigger Callback

This sample program installs an event handler and enables the trigger event. When the event occurs, the installed event handler is called. This program is intended to show specific VISA functionality and does not include error trapping. Error trapping, however, is good programming practice and is recommended in your VISA applications. See “Trapping Errors” in this chapter for more information.

This sample program is installed on your system in the `ProgrammingSamples` subdirectory. See the *IO Libraries Suite Online Help* for locations of sample programs.

```
/* evnthdlr.c
This example program illustrates installing an
event handler to be called when a trigger
interrupt occurs. Note that you may need to
change the address. */

#include <visa.h>
#include <stdio.h>

/* trigger event handler */
ViStatus _VI_FUNCH myHdlr(ViSession vi,
                          ViEventType eventType, ViEvent ctx, ViAddr
                          userHdlr){
    ViInt16 trigId;

    /* make sure it is a trigger event */
    if(eventType!=VI_EVENT_TRIG){
        /* Stray event, so ignore */
        return VI_SUCCESS;
    }

    /* print the event information */
    printf("Trigger Event Occurred!\n");
    printf("...Original Device Session = %ld\n",
          vi);

    /* get the trigger that fired */
    viGetAttribute(ctx, VI_ATTR_RECV_TRIG_ID,
                  &trigId);
}
```

```

printf("Trigger that fired: ");
switch(trigId){
    case VI_TRIG_TTL0:
        printf("TTL0");
        break;
    default:
        printf("<other 0x%x>", trigId);
        break;
}

printf("\n");

return VI_SUCCESS;
}

void main(){
ViSession defaultRM,vi;

/* open session to VXI device */
viOpenDefaultRM(&defaultRM);
viOpen(defaultRM, "VXI0::24::INSTR", VI_NULL,
        VI_NULL, &vi);

/* select trigger line TTL0 */
viSetAttribute(vi, VI_ATTR_TRIG_ID,
        VI_TRIG_TTL0);
/* install the handler and enable it */
viInstallHandler(vi, VI_EVENT_TRIG, myHdlr,
        (ViAddr)10);
viEnableEvent(vi, VI_EVENT_TRIG, VI_HNDLR,
        VI_NULL);
/* fire trigger line, twice */
viAssertTrigger(vi, VI_TRIG_PROT_SYNC);
viAssertTrigger(vi, VI_TRIG_PROT_SYNC);

/* unenable and uninstall the handler */
viDisableEvent(vi, VI_EVENT_TRIG, VI_HNDLR);

viUninstallHandler(vi, VI_EVENT_TRIG, myHdlr,
        (ViAddr)10);

```

```
/* close the sessions */
viClose(vi);
viClose(defaultRM);
}
```

Sample: SRQ Callback

This program installs an event handler and enables an SRQ event. When the event occurs, the installed event handler is called. This sample program is intended to show specific VISA functionality and does not include error trapping. Error trapping, however, is good programming practice and is recommended in your VISA applications. See “Trapping Errors” in this chapter for more information.

This program is installed on your system in the `ProgrammingSamples` subdirectory. See the *IO Libraries Suite Online Help* for locations of sample programs.

```
/* srqhdlr.c
This example program illustrates installing an
event handler to be called when an SRQ interrupt
occurs. Note that you may need to change the
address. */

#include <visa.h>
#include <stdio.h>
#if defined (_WIN32)
    #include <windows.h> /* for Sleep() */
    #define YIELD Sleep( 10 )

#elif defined (_WINDOWS)
    #include <io.h> /* for _wyield */
    #define YIELD _wyield()
#else
    #include <unistd.h>
    #define YIELD sleep( 1)
#endif

int srqOccurred;
```

```

/* trigger event handler */
ViStatus _VI_FUNCH mySrqHdlr(ViSession vi,
    ViEventType
    eventType, ViEvent ctx, ViAddr userHdlr){
    ViUInt16 statusByte;

    /* make sure it is an SRQ event */
    if(eventType!=VI_EVENT_SERVICE_REQ){
        /* Stray event, so ignore */
        printf( "\nStray event of type 0x%lx\n",
            eventType );
        return VI_SUCCESS;
    }

    /* print the event information */
    printf("\nSRQ Event Occurred!\n");
    printf("...Original Device Session = %ld\n",
        vi);

    /* get the status byte */
    viReadSTB(vi, &statusByte);
    printf("...Status byte is 0x%x\n",
        statusByte);

    srqOccurred = 1;
    return VI_SUCCESS;
}

void main(){
    ViSession defaultRM,vi;
    long count;

    /* open session to message based VXI device */
    viOpenDefaultRM(&defaultRM);
    viOpen(defaultRM, "GPIB-VXI0::24::INSTR",
        VI_NULL, VI_NULL, &vi);

    /* Enable command error events */
    viPrintf( vi, "*ESE 32\n" );

    /* Enable event register interrupts */
    viPrintf( vi, "*SRE 32\n" );

```

```
/* install the handler and enable it */
viInstallHandler(vi, VI_EVENT_SERVICE_REQ,
    mySrqHdlr,
    (ViAddr)10);
viEnableEvent(vi, VI_EVENT_SERVICE_REQ,
    VI_HNDLR, VI_NULL);

srqOccurred = 0;

/* Send a bogus command to the message-based
device to cause an SRQ. Note: 'IDN' causes the
error -- 'IDN?' is the correct syntax */
viPrintf( vi, "IDN\n" );

/* Wait a while for the SRQ to be generated and
for the handler to be called. Print something
while we wait */

printf("Waiting for an SRQ to be generated.");
for (count = 0 ; (count < 10) &&
    (srqOccurred == 0);count++) {
    long count2 = 0;
    printf( "." );
    while ( (count2++ < 100) && (srqOccurred ==0)
    ){YIELD;
    }
}
printf( "\n" );

/* disable and uninstall the handler */
viDisableEvent(vi, VI_EVENT_SERVICE_REQ,
    VI_HNDLR);
viUninstallHandler(vi, VI_EVENT_SERVICE_REQ,
    mySrqHdlr, (ViAddr)10);

/* Clean up - do not leave device in error
state */
viPrintf( vi, "*CLS\n" );

/* close the sessions */
viClose(vi);
viClose(defaultRM);

printf( "End of program\n" );}
```

Using the Queuing Method

The queuing method is generally used when an immediate response from your application is not needed. To use the queuing method for receiving notification that an event has occurred, you must do the following:

- Enable one or several events with the **viEnableEvent** function.
- When ready to query, use the **viWaitOnEvent** function to check for queued events.

If the specified event has occurred, the event information is retrieved and the program returns immediately. If the specified event has not occurred, the program suspends execution until a specified event occurs or until the specified timeout period is reached.

Sample: Using the Queuing Method

This sample program shows one way you can use the queuing method.

```
main();
ViSession vi;
ViEventType eventType;
ViEvent event;
.
.
viEnableEvent(vi, VI_EVENT_SERVICE_REQ,
              VI_QUEUE, VI_NULL);
.
.
viWaitOnEvent(vi, VI_EVENT_SERVICE_REQ,
              VI_TMO_INFINITE, &eventType, &event);
.
.
viClose(event);
viDisableEvent(vi, VI_EVENT_SERVICE_REQ,
               VI_QUEUE);
}
```

Enabling Events

Before an event can be delivered, it must be enabled using the **viEnableEvent** function:

```
viEnableEvent(vi, eventType, mechanism,
              context);
```

These parameters are defined as follows:

Table 23 Descriptions of Parameters Used to Enable Events

Parameter	Description
vi	The session the handler will be installed on.
eventType	The type of event to enable.
mechanism	The mechanism by which the event will be enabled. Specify VI_QUEUE to use the queuing method.
context	Not used in VISA 1.0. Use VI_NULL.

When you use VI_QUEUE in the *mechanism* parameter, you are specifying that the events will be put into a queue. Then, when a **viWaitOnEvent** function is invoked, the program execution will suspend until the enabled event occurs or the timeout period specified is reached. If the event has already occurred, the **viWaitOnEvent** function will return immediately.

Sample: Enabling a Hardware Trigger Event

This sample illustrates enabling a hardware trigger event.

```
viEnableEvent(vi, VI_EVENT_TRIG, VI_QUEUE,
              VI_NULL);
```

The VI_QUEUE mechanism specifies that when an event occurs, it will go into a queue. If you specify VI_ALL_ENABLE_EVENTS in the *eventType* parameter, all events that have previously been enabled on the specified session will be enabled for the *mechanism* specified in this function call. Use the **viDisableEvent** function to stop servicing the event specified.

Wait on the Event

When using the **viWaitOnEvent** function, specify the session, the event type to wait for, and the timeout period to wait:

```
viWaitOnEvent(vi, inEventType, timeout,
             outEventType, outContext);
```

The event must have previously been enabled with `VI_QUEUE` specified as the *mechanism* parameter.

Sample: Wait on Event for SRQ

This sample shows how to install a wait on event for service requests.

```
viEnableEvent(vi, VI_EVENT_SERVICE_REQ,
             VI_QUEUE, VI_NULL);
viWaitOnEvent(vi, VI_EVENT_SERVICE_REQ,
             VI_TMO_INFINITE, &eventType, &event);
.
.
viDisableEvent(vi, VI_EVENT_SERVICE_REQ,
             VI_QUEUE);
```

Every time a wait on event is invoked, an event context object is created. Specifying `VI_TMO_INFINITE` in the *timeout* parameter indicates that the program execution will suspend indefinitely until the event occurs. To clear the event queue for a specified event type, use the **viDiscardEvents** function.

Sample: Trigger Event Queuing

This program enables the trigger event in a queuing mode. When the **viWaitOnEvent** function is called, the program will suspend operation until the trigger line is fired or the timeout period is reached. Since the trigger lines were already fired and the events were put into a queue, the function will return and print the trigger line that fired.

This program is intended to show specific VISA functionality and does not include error trapping. Error trapping, however, is good programming practice and is recommended in your VISA applications. See “Trapping Errors” in this chapter for more information.

This sample program is installed on your system in the `ProgrammingSamples` subdirectory. See the *IO Libraries Suite Online Help* for locations of sample programs.

```
/* evntqueu.c
This sample program illustrates enabling an
event queue using viWaitOnEvent. Note that you
must change the device address. */

#include <visa.h>
#include <stdio.h>

void main(){
    ViSession defaultRM,vi;
    ViEventType eventType;
    ViEvent eventVi;
    ViStatus err;
    ViInt16 trigId;

    /* open session to VXI device */
    viOpenDefaultRM(&defaultRM);
    viOpen(defaultRM, "VXI0::24::INSTR", VI_NULL,
        VI_NULL, &vi);

    /* select trigger line TTL0 */
    viSetAttribute(vi, VI_ATTR_TRIG_ID,
        VI_TRIG_TTL0);

    /* enable the event */
    viEnableEvent(vi, VI_EVENT_TRIG, VI_QUEUE,
        VI_NULL);

    /* fire trigger line, twice */
    viAssertTrigger(vi, VI_TRIG_PROT_SYNC);
    viAssertTrigger(vi, VI_TRIG_PROT_SYNC);

    /* Wait for the event to occur */
    err=viWaitOnEvent(vi, VI_EVENT_TRIG, 10000,
        &eventType, &eventVi);
    if(err==VI_ERROR_TMO){
        printf("Timeout Occurred! Event not
            received.\n");
    }
    return;
}
```

```

/* print the event information */
printf("Trigger Event Occurred!\n");
printf("...Original Device Session = %ld\n",
    vi);

/* get trigger that fired */
viGetAttribute(eventVi, VI_ATTR_RECV_TRIG_ID,
    &trigId);
printf("Trigger that fired: ");
switch(trigId) {
case VI_TRIG_TTL0:
    printf("TTL0");
    break;
default:
    printf("<other 0x%x>", trigId);
    break;
}
printf("\n");

/* close the context before continuing */
viClose(eventVi);

/* get second event */
err=viWaitOnEvent(vi, VI_EVENT_TRIG, 10000,
    &eventType, &eventVi);
if(err==VI_ERROR_TMO) {
    printf("Timeout Occurred! Event not
        received.\n");
    return;
}
printf("Got second event\n");

/* close the context before continuing */
viClose(eventVi);

/* disable event */
viDisableEvent(vi, VI_EVENT_TRIG, VI_QUEUE);

/* close the sessions */
viClose(vi);
viClose(defaultRM);
}

```

Trapping Errors

This section provides guidelines for trapping errors, including:

- Trapping Errors
- Exception Events

Trapping Errors

The sample programs in this guide show specific VISA functionality and do not include error trapping. Error trapping, however, is good programming practice and is recommended in all your VISA application programs. To trap VISA errors you must check for VI_SUCCESS after each VISA function call.

If you want to ignore WARNINGS, you can test to see if **err** is less than (<) VI_SUCCESS. Since WARNINGS are greater than VI_SUCCESS and ERRORS are less than VI_SUCCESS, **err_handler** would only be called when the function returns an ERROR. For example:

```
if(err < VI_SUCCESS) err_handler (vi, err);
```

Sample: Checking for VI_SUCCESS

This sample illustrates checking for VI_SUCCESS. If VI_SUCCESS is not returned, an error handler (written by the programmer) is called. This must be done with each VISA function call.

```
ViStatus err;  
.  
.  
err=viPrintf(vi, "*RST\n");  
if (err < VI_SUCCESS) err_handler(vi, err);  
.  
.
```

Sample: Printing Error Code

The following error handler prints a user-readable string describing the error code passed to the function:

```
void err_handler(ViSession vi, ViStatus err){
```

```

char err_msg[1024]={0};
viStatusDesc (vi, err, err_msg);
printf ("ERROR = %s\n", err_msg);
return;
}

```

Sample: Checking Instrument Errors

When programming instruments, it is good practice to check the instrument to ensure there are no instrument errors after each instrument function. This sample uses a SCPI command to check a specific instrument for errors.

```

void system_err(){
    ViStatus err;
    char buf[1024]={0};
    int err_no;

    err=viPrintf(vi, "SYSTEM:ERR?\n");
    if (err < VI_SUCCESS) err_handler (vi, err);

    err=viScanf (vi, "%d\t", &err_no, &buf);
    if (err < VI_SUCCESS) err_handler (vi, err);

    while (err_no >0){
        printf ("Error Found: %d,%s\n", err_no,
            buf);
        err=viScanf (vi, "%d\t", &err_no, &buf);
    }
    err=viFlush(vi, VI_READ_BUF);
    if (err < VI_SUCCESS) err_handler (vi, err);

    err=viFlush(vi, VI_WRITE_BUF);
    if (err < VI_SUCCESS) err_handler (vi, err);
}

```

Exception Events

An alternative to trapping VISA errors by checking the return status after each VISA call is to use the VISA **exception event**. On sessions where an exception event handler is installed and VI_EVENT_EXCEPTION is enabled, the exception event handler is called whenever an error occurs while executing an operation.

Exception Handling Model

The exception-handling model follows the event-handling model for callbacks, and it uses the same operations as those used for general event handling. For example, an application calls **viInstallHandler** and **viEnableEvent** to enable exception events. The exception event is like any other event in VISA, except that the queuing and suspended handler mechanisms are not allowed.

When an error occurs for a session operation, the exception handler is executed synchronously. That is, the operation that caused the exception blocks until the exception handler completes its execution. The exception handler is executed in the context of the same thread that caused the exception event.

When invoked, the exception handler can check the error condition and instruct the exception operation to take a specific action. It can instruct the exception operation to continue normally (by returning `VI_SUCCESS`) or to not invoke any additional handlers in the case of handler nesting (by returning `VI_SUCCESS_NCHAIN`).

As noted, an exception operation blocks until the exception handler execution is completed. However, an exception handler sometimes may prefer to terminate the program prematurely without returning the control to the operation generating the exception. VISA does not preclude an application from using a platform-specific or language-specific exception handling mechanism from within the VISA exception handler.

For example, the C++ try/catch block can be used in an application in conjunction with the C++ throw mechanism from within the VISA exception handler. When using the C++ try/catch/throw or other exception-handling mechanisms, the control will not return to the VISA system. This has several important repercussions:

- 1 If multiple handlers were installed on the exception event, the handlers that were not invoked prior to the current handler will not be invoked for the current exception.
- 2 The exception context will not be deleted by the VISA system when a C++ exception is used. In this case, the application should delete the exception context as soon as the application has no more use for the context, before terminating the session. An application should use the **viClose** operation to delete the exception context.

- 3 Code in any operation (after calling an exception handler) may not be called if the handler does not return. For example, local allocations must be freed before invoking the exception handler, rather than after it.

One situation in which an exception event will not be generated is in the case of asynchronous operations. If the error is detected after the operation is posted (i.e., once the asynchronous portion has begun), the status is returned normally via the I/O completion event.

However, if an error occurs before the asynchronous portion begins (i.e., the error is returned from the asynchronous operation itself), then the exception event will still be raised. This deviation is due to the fact that asynchronous operations already raise an event when they complete, and this I/O completion event may occur in the context of a separate thread previously unknown to the application. In summary, a single application event handler can easily handle error conditions arising from both exception events and failed asynchronous operations.

Using the VI_EVENT_EXCEPTION Event

You can use the VI_EVENT_EXCEPTION event as notification that an error condition has occurred during an operation invocation. The following table describes the VI_EVENT_EXCEPTION event attributes.

Table 24 VI_EVENT_EXCEPTION Event Attributes.

Attribute Name	Access Privilege		Data Type	Range	Default
VI_ATTR_EVENT_TYPE	RO	Global	ViEventType	VI_EVENT_EXCEPTIO N	N/A
VI_ATTR_STATUS	RO	Global	ViStatus	N/A	N/A
VI_ATTR_OPER_NAME	RO	Global	ViString	N/A	N/A

Sample: Exception Events

```
/* This is an example of how to use exception
events to trap VISA errors. An exception event
handler must be installed and exception events
enabled on all sessions where the exception
handler is used.*/
```

```
#include <stdio.h>
#include <visa.h>
ViStatus __stdcall myExceptionHandler (
    ViSession vi,
    ViEventType eventType,
    ViEvent context,
    ViAddr usrHandle
) {
    ViStatus exceptionErrNbr;
    char    nameBuffer[256];
    ViString functionName = nameBuffer;
    char    errStrBuffer[256];
    /* Get the error value from the exception
       context */
    viGetAttribute( context, VI_ATTR_STATUS,
        &exceptionErrNbr );
    /* Get the function name from the exception
       context */
    viGetAttribute( context, VI_ATTR_OPER_NAME,
        functionName );
    errStrBuffer[0] = 0;
    viStatusDesc( vi, exceptionErrNbr,
        errStrBuffer );

    printf("ERROR: Exception Handler reports\n"
        "(%s)\n", "VISA function '%s' failed with
        error 0x%lx\n", "functionName,
        exceptionErrNbr, errStrBuffer );
    return VI_SUCCESS;
}
void main(){
    ViStatus  status;
```

```

ViSession drm;
ViSession vi;
ViAddr      myUserHandle = 0;

status = viOpenDefaultRM( &drm );
if ( status < VI_SUCCESS ) {
    printf( "ERROR: viOpenDefaultRM failed with
            error = 0x%lx\n", status );
    return;
}

/* Install the exception handler and enable
events for it */
status = viInstallHandler(drm,
    VI_EVENT_EXCEPTION, myExceptionHandler,
    myUserHandle);
if ( status < VI_SUCCESS )
{
    printf( "ERROR: viInstallHandler failed
            with error 0x%lx\n", status );
}

status = viEnableEvent(drm, VI_EVENT_EXCEPTION,
    VI_HNDLR, VI_NULL);
if ( status < VI_SUCCESS ) {
    printf( "ERROR: viEnableEvent failed with
            error 0x%lx\n", status );
}

/* Generate an error to demonstrate that the
handler will be called */
status = viOpen( drm, "badVisaName", NULL,
    NULL, &vi );
if ( status < VI_SUCCESS ) {
    printf("ERROR: viOpen failed with error
            0x%lx\n"
            "Exception Handler should have been
            called\n"
            "before this message was printed.\n", status
            );
}
}

```

Using Locks

In VISA, applications can open multiple sessions to a VISA resource simultaneously. Applications can, therefore, access a VISA resource concurrently through different sessions. However, in certain cases, applications accessing a VISA resource may want to restrict other applications from accessing that resource.

Lock Functions

For example, when an application needs to perform successive write operations on a resource, the application may require that, during the sequence of writes, no other operation can be invoked through any other session to that resource. For such circumstances, VISA defines a locking mechanism that restricts access to resources.

The VISA locking mechanism enforces arbitration of accesses to VISA resources on a per-session basis. If a session locks a resource, operations invoked on the resource through other sessions either are serviced or are returned with an error, depending on the operation and the type of lock used.

If a VISA resource is not locked by any of its sessions, all sessions have full privilege to invoke any operation and update any global attributes. Sessions are *not* required to have locks to invoke operations or update global attributes. However, if some other session has already locked the resource, attempts to update global attributes or invoke certain operations will fail.

See descriptions of the individual VISA functions in the *VISA Online Help* to determine which would fail when a resource is locked.

viLock/viUnlock Functions

The VISA **viLock** function is used to acquire a lock on a resource.

```
viLock(vi, lockType, timeout, requestedKey,  
      accessKey);
```

The VI_ATTR_RSRC_LOCK_STATE attribute specifies the current locking state of the resource on the given session, which can be either VI_NO_LOCK, VI_EXCLUSIVE_LOCK, or VI_SHARED_LOCK.

The VISA **viUnlock** function is then used to release the lock on a resource. If a resource is locked and the current session does not have the lock, the error `VI_ERROR_RSRC_LOCKED` is returned.

VISA Lock Types

VISA defines two different types of locks: **Exclusive Lock** and **Shared Lock**.

Exclusive Lock - A session can lock a VISA resource using the lock type `VI_EXCLUSIVE_LOCK` to get exclusive access privileges to the resource. This exclusive lock type excludes access to the resource from all other sessions.

If a session has an exclusive lock, other sessions cannot modify global attributes or invoke operations on the resource. However, the other sessions *can* still get attributes.

Shared Lock - A session can share a lock on a VISA resource with other sessions by using the lock type `VI_SHARED_LOCK`. Shared locks in VISA are similar to exclusive locks in terms of access privileges, but can still be shared between multiple sessions.

If a session has a shared lock, other sessions that share the lock can also modify global attributes and invoke operations on the resource (of course, unless some other session has a previous exclusive lock on that resource). A session that does not share the lock will lack these capabilities.

Locking a resource restricts access from other sessions, and in the case where an exclusive lock is acquired, ensures that operations do not fail because other sessions have acquired a lock on that resource. Thus, locking a resource prevents other, subsequent sessions from acquiring an exclusive lock on that resource. Yet, when multiple sessions have acquired a shared lock, VISA allows one of the sessions to acquire an exclusive lock along with the shared lock it is holding.

Also, VISA supports nested locking. That is, a session can lock the same VISA resource multiple times (for the same lock type) via multiple invocations of the **viLock** function. In such a case, unlocking the resource requires an equal number of invocations of the **viUnlock** function. Nested locking is explained in detail later in this section.

Some VISA operations may be permitted even when there is an exclusive lock on a resource, or some global attributes may not be read when there is any kind of lock on the resource. These exceptions, when applicable, are mentioned in the descriptions of the individual VISA functions and attributes.

See the *VISA Online Help* for descriptions of individual functions to determine which are applicable for locking and which are not restricted by locking.

Sample: Exclusive Lock

This sample shows a session gaining an exclusive lock to perform the **viPrintf** and **viScanf** VISA operations on a GPIB device. It then releases the lock via the **viUnlock** function.

```
/* lockexcl.c
This example program queries a GPIB device for
an identification string and prints the results.
Note that you may need to change the address. */
#include <visa.h>
#include <stdio.h>

void main () {
    ViSession defaultRM, vi;
    char buf [256] = {0};

    /* Open session to GPIB device at address 22 */
    viOpenDefaultRM (&defaultRM);
    viOpen (defaultRM, "GPIB0::22::INSTR",
           VI_NULL,VI_NULL, &vi);

    /* Initialize device */
    viPrintf (vi, "*RST\n");

    /* Make sure no other process or thread does
    anything to this resource between viPrintf and
    viScanf calls */

    viLock (vi, VI_EXCLUSIVE_LOCK, 2000, VI_NULL,
           VI_NULL);
```

```

/* Send an *IDN? string to the device */
viPrintf (vi, "*IDN?\n");

/* Read results */
viScanf (vi, "%t", &buf);

/* Unlock this session so other processes and
threads can use it */
viUnlock (vi);

/* Print results */
printf ("Instrument identification string:
      %s\n", buf);

/* Close session */
viClose (vi);
viClose (defaultRM);}

```

Sample: Shared Lock

This sample shows a session gaining a shared lock with the *accessKey* called **lockkey**. Other sessions can now use this *accessKey* in the *requestedKey* parameter of the **viLock** function to share access on the locked resource. This sample then shows the original session acquiring an exclusive lock while maintaining its shared lock.

When the session holding the exclusive lock unlocks the resource via the **viUnlock** function, all the sessions sharing the lock again have all the access privileges associated with the shared lock.

```

/* lockshr.c
This example program queries a GPIB device for
an identification string and prints the results.
Note that you must change the address. */

#include <visa.h>
#include <stdio.h>

void main () {

    ViSession defaultRM, vi;
    char buf [256] = {0};
    char lockkey [256] = {0};

```

3 Programming with VISA

```
/* Open session to GPIB device at address 22 */
viOpenDefaultRM (&defaultRM);
viOpen (defaultRM, "GPIB0::22::INSTR",
        VI_NULL,VI_NULL,&vi);

/* acquire a shared lock so only this process
and processes that we know about can access
this resource */
viLock (vi, VI_SHARED_LOCK, 2000, VI_NULL,
        lockkey);

/* at this time, we can make 'lockkey'
available to other processes that we know
about. This can be done with shared memory or
other inter-process communication methods.
These other processes can then call
"viLock(vi,VI_SHARED_LOCK, 2000, lockkey,
lockkey)" and they will also have access to
this resource. */

/* Initialize device */
viPrintf (vi, "*RST\n");

/* Make sure no other process or thread does
anything to this resource between the
viPrintf() and the viScanf()calls Note: this
also locks out the processes with which we
shared our 'shared lock' key. */

viLock (vi, VI_EXCLUSIVE_LOCK, 2000,
        VI_NULL,VI_NULL);

/* Send an *IDN? string to the device */
viPrintf (vi, "*IDN?\n");

/* Read results */
viScanf (vi, "%t", &buf);

/* unlock this session so other processes and
threads can use it */
viUnlock (vi);

/* Print results */
printf ("Instrument identification string:
        %s\n", buf);
```



```
/* release the shared lock also*/  
viUnlock (vi);  
  
/* Close session */  
viClose (vi);  
viClose (defaultRM);  
}
```

3 Programming with VISA

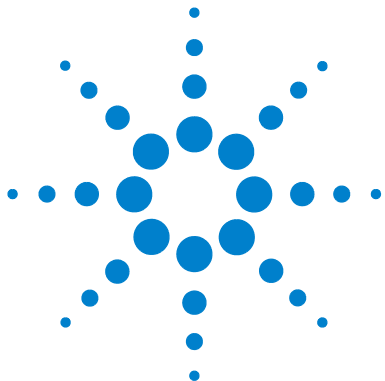

4 Programming via GPIB and VXI

VISA supports three interfaces you can use to access GPIB (General Purpose Interface Bus) and VXI (VME eXtension for Instrumentation) instruments: GPIB, VXI, and GPIB-VXI.

This chapter provides information to program GPIB and VXI devices via the GPIB, VXI or GPIB-VXI interfaces, including:

- GPIB and VXI Interfaces Overview
- Using High-Level Memory Functions
- Using Low-Level Memory Functions
- Using High/Low-Level Memory I/O Methods
- Using the Memory Access Resource
- Using VXI-Specific Attributes

See Chapter 3, “Programming with VISA”, for general information on VISA programming for the GPIB, VXI, and GPIB-VXI interfaces. See the *VISA Online Help* for information on the specific VISA functions.



GPIB and VXI Interfaces Overview

This section provides an overview of the GPIB, GPIB-VXI, and VXI interfaces, including:

- General Interface Information
- GPIB Interfaces Overview
- VXI Interfaces Overview

General Interface Information

VISA supports three interfaces you can use to access instruments or devices: GPIB, VXI, and GPIB-VXI. The GPIB interface can be used to access VXI instruments via a Command Module. In addition, the VXI backplane can be directly accessed with the VXI or GPIB-VXI interfaces.

What is an I/O Interface?

An **I/O interface** can be defined as both a hardware interface and as a software interface. Connection Expert is used to associate a unique interface name with a hardware interface. Agilent IO Libraries Suite uses a **VISA interface name** to identify an interface. This information is passed in the parameter string of the **viOpen** function call in a VISA program.

Connection Expert assigns a VISA interface name to the interface hardware, and other necessary configuration values for an interface when the interface is configured. See the *Agilent IO Libraries Suite Online Help* for details.

VXI Device Types

When using GPIB-VXI or VXI interfaces to directly access the VXI backplane (in the VXI mainframe), you must know whether you are programming a message-based or a register-based VXI device (instrument).

A **message-based VXI device** has its own processor that allows it to interpret high-level commands such as Standard Commands for Programmable Instruments (SCPI). When using VISA, you can place the SCPI command within your VISA output function call. Then, the

message-based device interprets the SCPI command. In this case you can use the VISA formatted I/O or non-formatted I/O functions and program the message-based device as you would a GPIB device.

However, if the message-based device has shared memory, you can access the device's shared memory by doing register peeks and pokes. VISA provides two different methods you can use to program directly to the registers: high-level memory functions or low-level memory functions.

A **register-based VXI device** typically does not have a processor to interpret high-level commands. Therefore, the device must be programmed with register peeks and pokes directly to the device's registers. VISA provides two different methods you can use to program register-based devices: high-level memory functions or low-level memory functions.

GPIB Interfaces Overview

As shown in the following figure, a typical GPIB interface consists of a Windows PC with one or more GPIB cards (PCI and/or ISA) cards installed in the PC, and one or more GPIB instruments connected to the GPIB cards via GPIB cable. I/O communication between the PC and the instruments is via the GPIB cards and the GPIB cable. The following figure shows GPIB instruments at addresses 3 and 5.

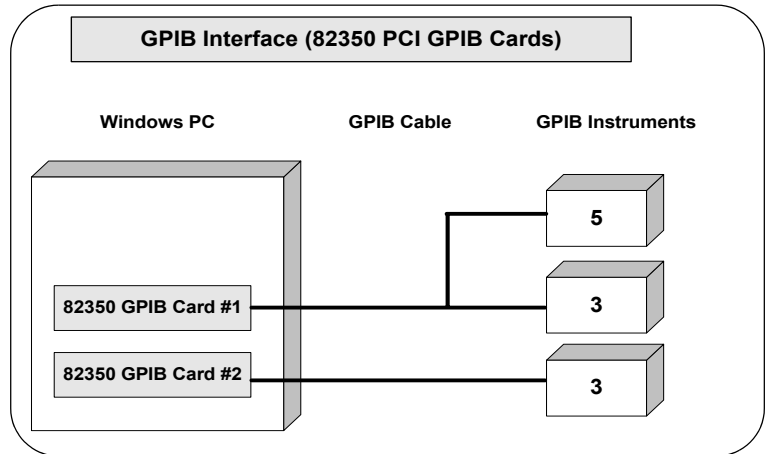

Example: GPIB (82350) Interface

The GPIB interface system in the following figure consists of a Windows PC with two 82350 GPIB cards connected to three GPIB instruments via GPIB cables. For this system, Agilent Connection Expert has been used to assign GPIB card #1 a VISA name of **GPIB0** and to assign GPIB card #2 a VISA name of **GPIB1**. VISA addressing is as shown in the figure.

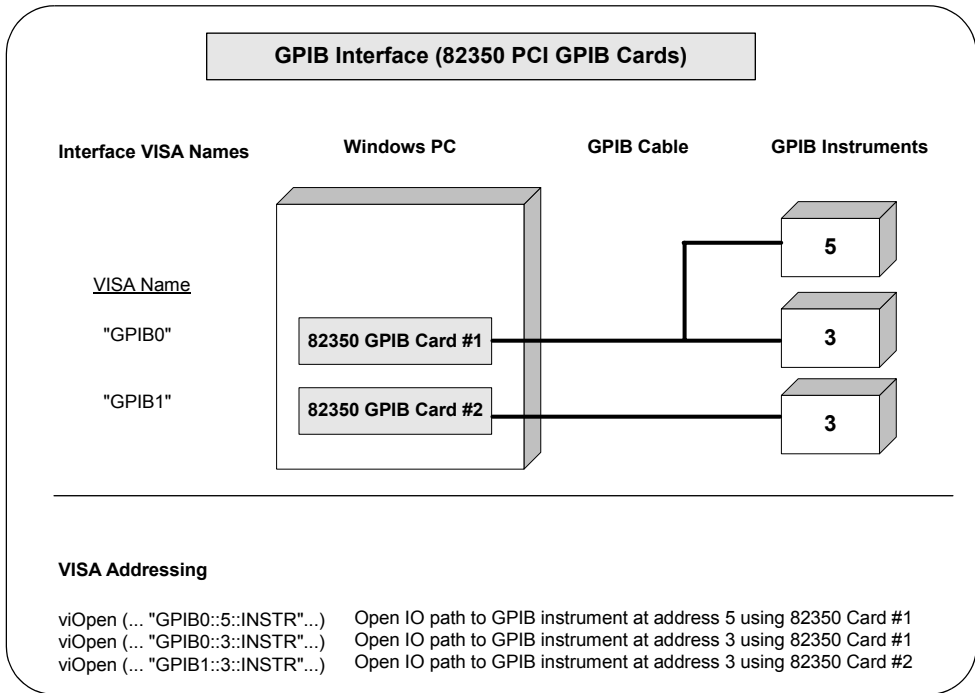

VXI Interfaces Overview

As shown in the following figure, a typical VXI (E8491) interface consists of an E8491 PC Card in a Windows PC that is connected to an E8491B IEEE-1394 Module in a VXI mainframe via an IEEE-1394 to VXI cable. The VXI mainframe also includes one or more VXI instruments.

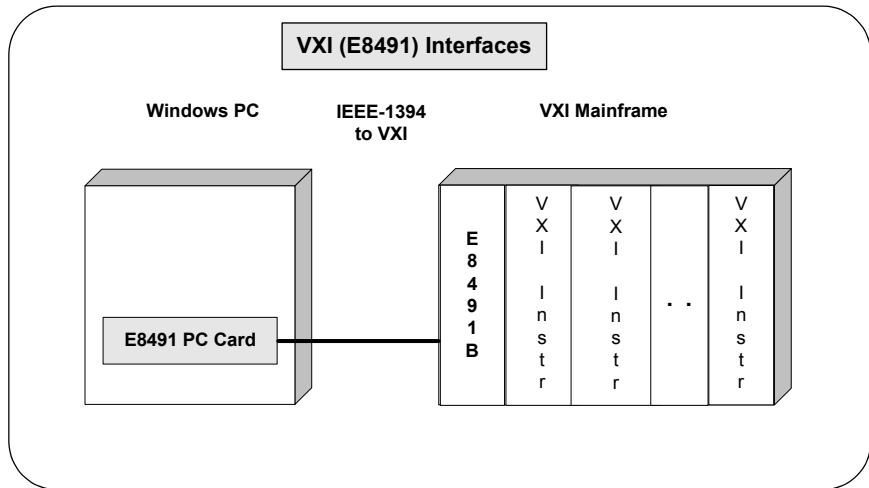

Example: VXI (E8491B) Interfaces

The VXI interface system in the following figure consists of a Windows PC with an E8491 PC card that connects to an E8491B IEEE-1394 to VXI Module in a VXI Mainframe. For this system, the three VXI instruments shown have logical addresses 8, 16, and 24. The Connection Expert utility has been used to assign the E8491 PC card a VISA name of **VXI0**. VISA addressing is as shown in the figure.

For information on the E8491B module, see the *Agilent E8491B User's Guide*. For information on VXI instruments, see the applicable VXI instrument *User's Guide*.

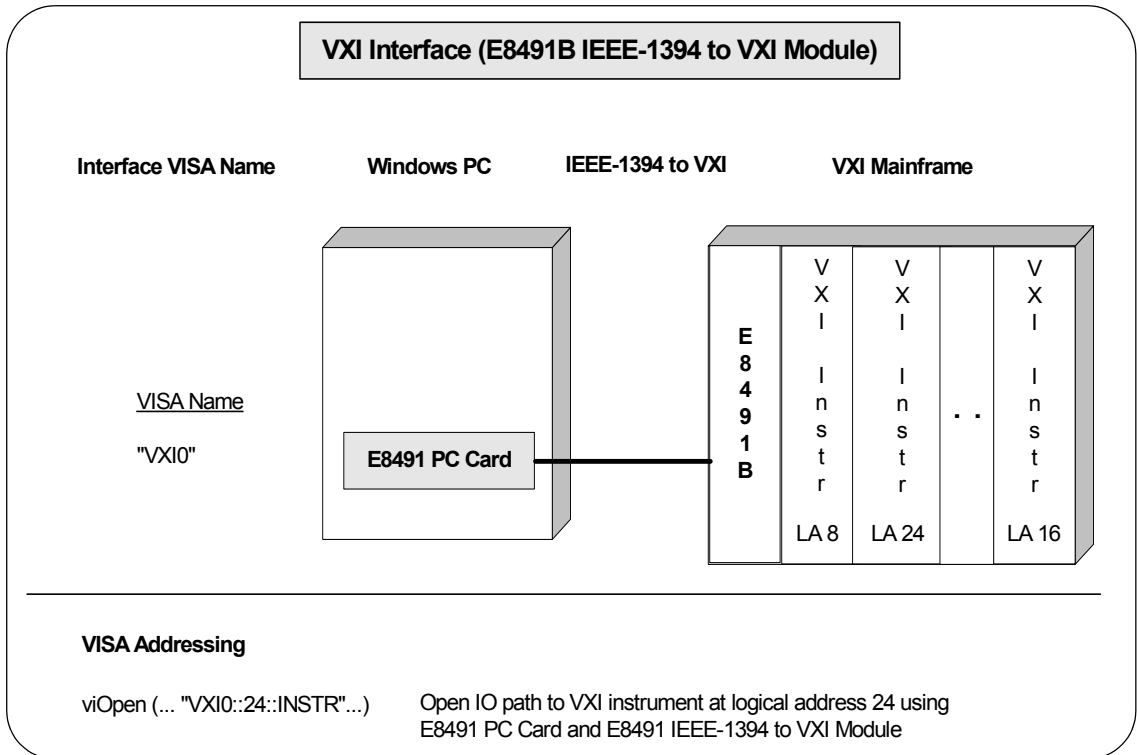

GPIB-VXI Interfaces Overview

As shown in the following figure, a typical GPIB-VXI interface consists of a GPIB card (82350 or equivalent) in a Windows PC that is connected via a GPIB cable to an E1406A Command Module. The E1406A sends commands to the VXI instruments in a VXI mainframe. There is no direct access to the VXI backplane from the PC.

NOTE

For a GPIB-VXI interface, VISA uses a DLL supplied by the Command Module vendor to translate the VISA VXI calls to Command Module commands that are vendor-specific. The DLL required for Agilent Command Modules is installed by the Agilent IO Libraries Suite installer. This DLL is installed by default when Agilent VISA is installed.

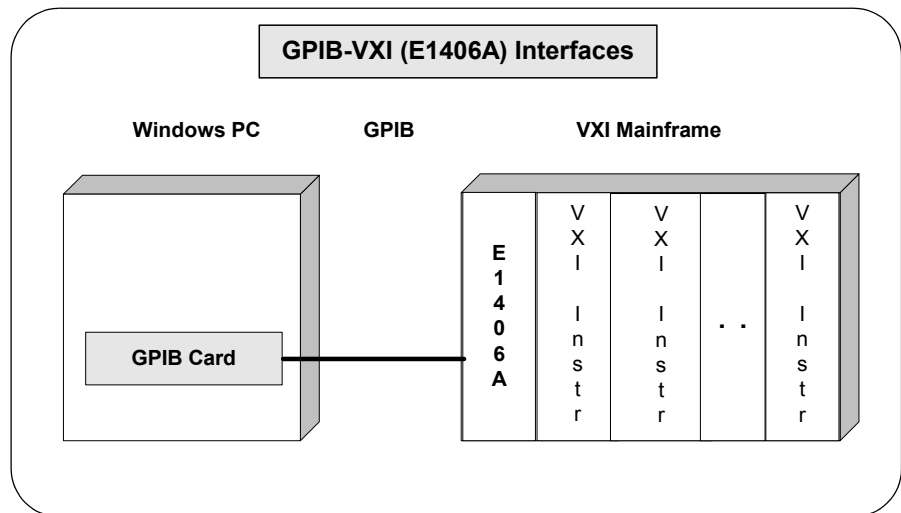

Example: GPIB-VXI (E1406A) Interface

The GPIB-VXI interface system in the following figure consists of a Windows PC with an Agilent 82350 GPIB card that connects to an E1406A command module in a VXI mainframe. The VXI mainframe includes one or more VXI instruments.

When Agilent IO Libraries Suite was installed, a GPIB-VXI driver with GPIB address 9 was also installed, and the E1406A was configured for primary address 9 and logical address (LA) 0. The three VXI instruments shown have logical addresses 8, 16, and 24.

The Connection Expert utility has been used to assign the GPIB-VXI driver a VISA name of **GPIB-VXI0** and to assign the 82350 GPIB card a VISA name of **GPIB0**. VISA addressing is as shown in the figure.

For information on the E1406A Command Module, see the *Agilent E1406A Command Module User's Guide*. For information on VXI instruments, see the applicable instrument's *User's Guide*.

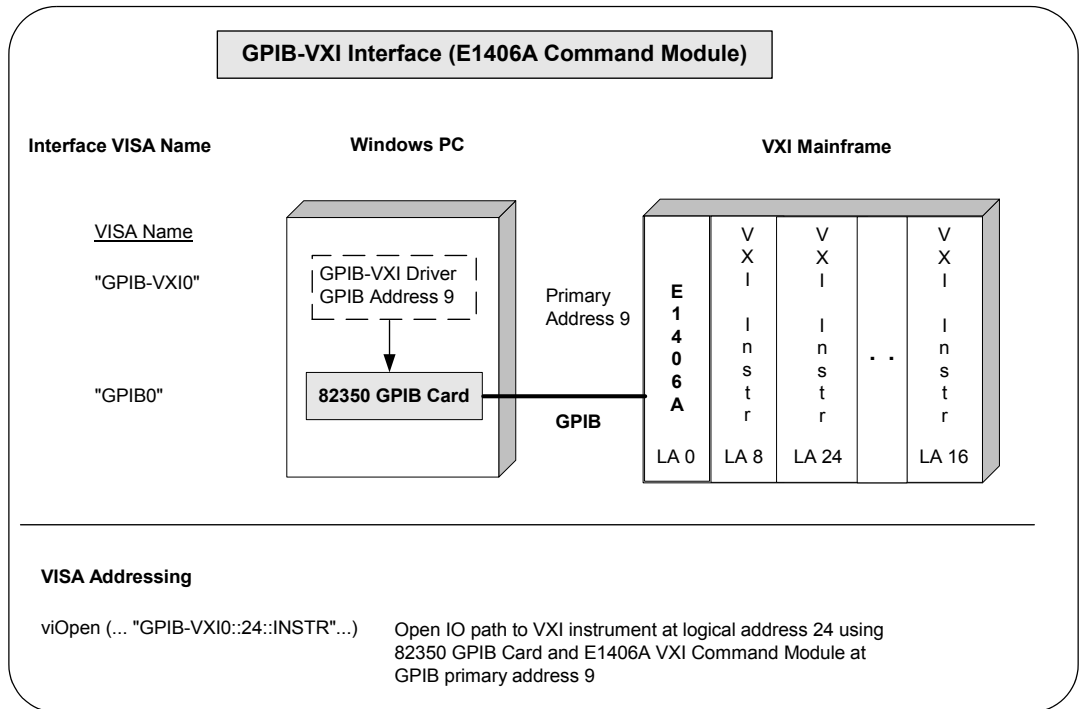

Using High-Level Memory Functions

High-level memory functions allow you to access memory on the interface through simple function calls. There is no need to map memory to a window. Instead, when high-level memory functions are used, memory mapping and direct register access are automatically done.

The trade-off, however, is speed. High-level memory functions are easier to use. However, since these functions encompass mapping of memory space and direct register access, the associated overhead slows program execution time. If speed is required, use the low-level memory functions discussed in “Using Low-Level Memory Functions” on page 106.

Programming the Registers

High-level memory functions include the **viIn** and **viOut** functions for transferring 8-, 16-, or 32-bit values, as well as the **viMoveIn** and **viMoveOut** functions for transferring 8-, 16-, or 32-bit blocks of data into or out of local memory. You can therefore program using 8-, 16-, or 32-bit transfers.

High-Level Memory Functions

This table summarizes the high-level memory functions.

Table 25 Summary of High-Level Memory Functions

Function	Description
viIn8 (<i>vi, space, offset, val8</i>);	Reads 8 bits of data from the specified offset.
viIn16 (<i>vi, space, offset, val16</i>);	Reads 16 bits of data from the specified offset.
viIn32 (<i>vi, space, offset, val32</i>);	Reads 32 bits of data from the specified offset.
viOut8 (<i>vi, space, offset, val8</i>);	Writes 8 bits of data to the specified offset.

Table 25 Summary of High-Level Memory Functions

viOut16 (<i>vi, space, offset, val16</i>);	Writes 16 bits of data to the specified offset.
viOut32 (<i>vi, space, offset, val32</i>);	Writes 32 bits of data to the specified offset.
viMoveIn8 (<i>vi, space, offset, length, buf8</i>);	Moves an 8-bit block of data from the specified offset to local memory.
viMoveIn16 (<i>vi, space, offset, length, buf16</i>);	Moves a 16-bit block of data from the specified offset to local memory.
viMoveIn32 (<i>vi, space, offset, length, buf32</i>);	Moves a 32-bit block of data from the specified offset to local memory.
viMoveOut8 (<i>vi, space, offset, length, buf8</i>);	Moves an 8-bit block of data from local memory to the specified offset.
viMoveOut16 (<i>vi, space, offset, length, buf16</i>);	Moves a 16-bit block of data from local memory to the specified offset.
viMoveOut32 (<i>vi, space, offset, length, buf32</i>);	Moves a 32-bit block of data from local memory to the specified offset.

Using *viIn* and *viOut*

When using the **viIn** and **viOut** high-level memory functions to program to the device registers, all you need to specify is the session identifier, address space, and the offset of the register. Memory mapping is done for you. For example, in this function:

```
viIn32(vi, space, offset, val32);
```

vi is the session identifier and *offset* is used to indicate the offset of the memory to be mapped. *offset* is relative to the location of this device's memory in the given address space. The *space* parameter determines which memory location to map the space. Valid *space* values are:

- **VI_A16_SPACE** - Maps in VXI/MXI A16 address space
- **VI_A24_SPACE** - Maps in VXI/MXI A24 address space
- **VI_A32_SPACE** - Maps in VXI/MXI A32 address space

The *val32* parameter is a pointer to where the data read will be stored. If instead you write to the registers via the **viOut32** function, the *val32* parameter is a pointer to the data to write to the specified registers. If the device specified by *vi* does not have memory in the specified address space, an error is returned. The following code sample uses **viIn16**.

```
ViSession defaultRM, vi;
ViUInt16 value;

.
viOpenDefaultRM(&&defaultRM);
viOpen(defaultRM, "VXI::24", VI_NULL, VI_NULL,
&vi);
viIn16(vi, VI_A16_SPACE, 0x100, &value);
```

Using **viMoveIn** and **viMoveOut**

You can also use the **viMoveIn** and **viMoveOut** high-level memory functions to move blocks of data to or from local memory. Specifically, the **viMoveIn** function moves an 8-, 16-, or 32-bit block of data from the specified offset to local memory, and the **viMoveOut** functions moves an 8-, 16-, or 32-bit block of data from local memory to the specified offset. Again, the memory mapping is done for you.

For example, in this function:

```
viMoveIn32(vi, space, offset, length, buf32);
```

vi is the session identifier and *offset* is used to indicate the offset of the memory to be mapped. *offset* is relative to the location of this device's memory in the given address space. The *space* parameter determines which memory location to map the space and the *length* parameter specifies the number of elements to transfer (8-, 16-, or 32-bits).

The *buf32* parameter is a pointer to where the data read will be stored. If instead you write to the registers via the **viMoveOut32** function, the *buf32* parameter is a pointer to the data to write to the specified registers.

High-Level Memory Functions: Sample Programs

Two sample programs follow that use the high-level memory functions to read the ID and Device Type registers of a device at the VXI logical address 24. The contents of the registers are then printed out.

The first program uses the VXI interface; the second program accesses the backplane with the GPIB-VXI interface. These two programs are identical except for the string passed to **viOpen**.

Sample: Using VXI Interface (High-Level) Memory Functions

This program uses high-level memory functions and the VXI interface to read the ID and Device Type registers of a device at VXI0::24.

```

/* vxihl.c
This example program uses the high-level memory
functions to read the id and device type
registers of the device at VXI0::24. Change this
address if necessary. The register contents are
then displayed.*/

#include <visa.h>
#include <stdlib.h>
#include <stdio.h>

void main () {

    ViSession defaultRM, dmm;
    unsigned short id_reg, devtype_reg;

    /* Open session to VXI device at address 24 */
    viOpenDefaultRM(&defaultRM);
    viOpen(defaultRM, "VXI0::24::INSTR", VI_NULL,
    VI_NULL, &dmm);

    /* Read instrument id register contents */
    viIn16(dmm, VI_A16_SPACE, 0x00, &id_reg);

    /* Read device type register contents */
    viIn16(dmm, VI_A16_SPACE, 0x02,
    &devtype_reg);

    /* Print results */
    printf ("ID Register = 0x%4X\n", id_reg);
    printf ("Device Type Register = 0x%4X\n",
    devtype_reg);
}

```

```
    /* Close sessions */
    viClose(dmm);
    viClose(defaultRM);
}
```

Sample: Using GPIB-VXI Interface (High-Level) Memory Functions

This program uses high-level memory functions and the GPIB-VXI interface to read the ID and Device Type registers of a device at GPIB-VXI0::24.

```
/*gpibvxih.c
This example program uses the high-level memory
functions to read the id and device type
registers of the device at GPIB-VXI0::24. Change
this address if necessary. The register
contents are then displayed.*/

#include <visa.h>
#include <stdlib.h>
#include <stdio.h>

void main ()
{
    ViSession defaultRM, dmm;
    unsigned short id_reg, devtype_reg;

    /* Open session to VXI device at address 24 */
    viOpenDefaultRM(&defaultRM);
    viOpen(defaultRM, "GPIB-VXI0::24::INSTR",
    VI_NULL,VI_NULL, &dmm);

    /* Read instrument id register contents */
    viIn16(dmm, VI_A16_SPACE, 0x00, &id_reg);

    /* Read device type register contents */
    viIn16(dmm, VI_A16_SPACE, 0x02,
    &devtype_reg);
}
```



```
/* Print results */  
printf ("ID Register = 0x%4X\n", id_reg);  
printf ("Device Type Register = 0x%4X\n",  
devtype_reg);  
  
/* Close sessions */  
viClose(dmm);  
viClose(defaultRM);  
}
```

Using Low-Level Memory Functions

Low-level memory functions allow direct access to memory on the interface just as do high-level memory functions. However, with low-level memory function calls, you must map a range of addresses and directly access the registers with low-level memory functions, such as **viPeek32** and **viPoke32**.

There is more programming effort required when using low-level memory functions. However, the program execution speed can increase. Additionally, to increase program execution speed, the low-level memory functions do not return error codes.

Programming the Registers

When using the low-level memory functions for direct register access, you must first map a range of addresses using the **viMapAddress** function. Next, you can send a series of peeks and pokes using the **viPeek** and **viPoke** low-level memory functions. Then, you must free the address window using the **viUnmapAddress** function. A process you could use is:

- 1 Map memory space using **viMapAddress**.
- 2 Read and write to the register's contents using **viPeek32** and **viPoke32**.
- 3 Unmap the memory space using **viUnmapAddress**.

Low-Level Memory Functions

You can program the registers using low-level functions for 8-, 16-, or 32-bit transfers. This table summarizes the low-level memory functions.

Table 26 Summary of Low-Level Memory Functions

Function	Description
viMapAddress (<i>vi</i> , <i>mapSpace</i> , <i>mapBase</i> , <i>mapSize</i> , <i>access</i> , <i>suggested</i> , <i>address</i>);	Maps the specified memory space.
viPeek8 (<i>vi</i> , <i>addr</i> , <i>val8</i>);	Reads 8 bits of data from address specified.

Table 26 Summary of Low-Level Memory Functions (continued)

viPeek16 (<i>vi, addr, val16</i>);	Reads 16 bits of data from address specified.
viPeek32 (<i>vi, addr, val32</i>);	Reads 32 bits of data from address specified.
viPoke8 (<i>vi, addr, val8</i>);	Writes 8 bits of data to address specified.
viPoke16 (<i>vi, addr, val16</i>);	Writes 16 bits of data to address specified.
viPoke32 (<i>vi, addr, val32</i>);	Writes 32 bits of data to address specified.
viUnmapAddress (<i>vi</i>);	Unmaps memory space previously mapped.

Mapping Memory Space

When using VISA to access the device's registers, you must map memory space into your process space. For a given session, you can have only one map at a time. To map space into your process, use the VISA **viMapAddress** function:

```
viMapAddress(vi, mapSpace, mapBase, mapSize,
            access, suggested, address);
```

This function maps space for the device specified by the *vi* session. *mapBase*, *mapSize*, and *suggested* are used to indicate the offset of the memory to be mapped, amount of memory to map, and a suggested starting location, respectively. *mapSpace* determines which memory location to map the space. The following are valid *mapSpace* choices:

VI_A16_SPACE - Maps in VXI/MXI A16 address space

VI_A24_SPACE - Maps in VXI/MXI A24 address space

VI_A32_SPACE - Maps in VXI/MXI A32 address space

A pointer to the address space where the memory was mapped is returned in the *address* parameter. If the device specified by *vi* does not have memory in the specified address space, an error is returned. Some sample **viMapAddress** function calls follow.

```
/* Maps to A32 address space */
viMapAddress(vi, VI_A32_SPACE, 0x000, 0x100,
            VI_FALSE,
            VI_NULL, &address);
```

```
/* Maps to A24 address space */  
viMapAddress(vi, VI_A24_SPACE, 0x00, 0x80,  
VI_FALSE,  
VI_NULL, &address);
```

Reading and Writing to Device Registers

When you have mapped the memory space, use the VISA low-level memory functions to access the device's registers. First, determine which device register you need to access. Then, you need to know the register's offset. See the applicable instrument's user manual for a description of the registers and register locations. You can then use this information and the VISA low-level functions to access the device registers.

Sample: Using *viPeek16*

A code sample using **viPeek16** follows.

```
ViSession defaultRM, vi;  
ViUInt16 value;  
ViAddr address;  
ViUInt16 value;  
.  
.  
viOpenDefaultRM(&&defaultRM);  
viOpen(defaultRM, "VXI::24::INSTR", VI_NULL,  
VI_NULL,  
vi);  
viMapAddress(vi, VI_A16_SPACE, 0x00, 0x04,  
VI_FALSE,  
VI_NULL, &address);  
viPeek16(vi, addr, &value)
```

Unmapping Memory Space

Make sure you use the **viUnmapAddress** function to unmap the memory space when it is no longer needed. Unmapping memory space makes the window available for the system to reallocate.

Low-Level Memory Functions: Code Samples

Two sample programs follow that use the low-level memory functions to read the ID and Device Type registers of the device at VXI logical address 24. The contents of the registers are then printed out. The first program uses the VXI interface and the second program uses the GPIB-VXI interface to access the VXI backplane. These two programs are identical except for the string passed to **viOpen**.

Sample: Using the VXI Interface (Low-Level) Memory Functions

This program uses low-level memory functions and the VXI interface to read the ID and Device Type registers of a device at VXI0::24.

```

/*vxill.c
This example program uses the low-level memory
functions to read the id and device type
registers of the device at VXI0::24. Change this
address if necessary. The register contents are
then displayed.*/

#include <visa.h>
#include <stdlib.h>
#include <stdio.h>

void main () {

    ViSession defaultRM, dmm;
    ViAddr address;
    unsigned short id_reg, devtype_reg;

    /* Open session to VXI device at address 24 */
    viOpenDefaultRM(&defaultRM);
    viOpen(defaultRM, "VXI0::24::INSTR", VI_NULL,
           VI_NULL, &dmm);

    /* Map into memory space */
    viMapAddress(dmm, VI_A16_SPACE, 0x00, 0x10,
                VI_FALSE,VI_NULL, &address);

    /* Read instrument id register contents */
    viPeek16(dmm, address, &id_reg);

```

```
/* Read device type register contents */
/* ViAddr is defined as a void so we must cast
/* it to something else to do pointer
   arithmetic */
viPeek16(dmm, (ViAddr)((ViUInt16 *)address +
0x01),
    &devtype_reg);

/* Unmap memory space */
viUnmapAddress(dmm);

/* Print results */
printf ("ID Register = 0x%4X\n", id_reg);
printf ("Device Type Register = 0x%4X\n",
    devtype_reg);

/* Close sessions */
viClose(dmm);
viClose(defaultRM);
}
```

Sample: Using the GPIB-VXI Interface (Low-Level) Memory Functions

This program uses low-level memory functions and the GPIB-VXI interface to read the ID and Device Type registers of a device at GPIB-VXI0::24.

```
/*gpibvxil.c
This example program uses the low-level memory
functions to read the id and device type
registers of the device at GPIB-VXI0::24. Change
this address if necessary. Register contents are
then displayed.*/

#include <visa.h>
#include <stdlib.h>
#include <stdio.h>

void main () {

    ViSession defaultRM, dmm;
    ViAddr address;
    unsigned short id_reg, devtype_reg;
```

```

/* Open session to VXI device at address 24 */
viOpenDefaultRM(&defaultRM);
viOpen(defaultRM, "GPIB-VXI0::24::INSTR",
        VI_NULL,
        VI_NULL, &dmm);

/* Map into memory space */
viMapAddress(dmm, VI_A16_SPACE, 0x00, 0x10,
            VI_FALSE,
            VI_NULL, &address);

/* Read instrument id register contents */
viPeek16(dmm, address, &id_reg);

/* Read device type register contents */
/* ViAddr is defined as a void so we must
   cast it to something else to do pointer
   arithmetic */
viPeek16(dmm, (ViAddr)((ViUInt16 *)address +
                    0x01),
        &devtype_reg);

/* Unmap memory space */
viUnmapAddress(dmm);

/* Print results */
printf ("ID Register = 0x%4X\n", id_reg);
printf ("Device Type Register = 0x%4X\n",
        devtype_reg);

/* Close sessions */
viClose(dmm);
viClose(defaultRM);
}

```

Using Low/High-Level Memory I/O Methods

VISA supports three different memory I/O methods for accessing memory on the VXI backplane, as shown. All three of these access methods can be used to read and write VXI memory in the A16, A24, and A32 address spaces. The best method to use depends on the VISA program characteristics.

- Low-level **viPeek/viPoke**
 - **viMapAddress**
 - **viUnmapAddress**
 - **viPeek8, viPeek16, viPeek32**
 - **viPoke8, viPoke16, viPoke32**

- High-level **viIn/viOut**
 - **viIn8, viIn16, viIn32**
 - **viOut8, viOut16, viOut32**

- High-level **viMoveIn/viMoveOut**
 - **viMoveIn8, viMoveIn16, viMoveIn32**
 - **viMoveOut8, viMoveOut16, viMoveOut32**

Using Low-Level viPeek/viPoke

Low-level **viPeek/viPoke** is the most efficient in programs that require repeated access to different addresses in the same memory space.

The advantages of low-level **viPeek/viPoke** are:

- Individual **viPeek/viPoke** calls are faster than **viIn/viOut** or **viMoveIn/viMoveOut** calls.
- Memory pointers may be directly de-referenced in some cases for the lowest possible overhead.

The disadvantages of low-level **viPeek/viPoke** are:

- A **viMapAddress** call is required to set up mapping before **viPeek/viPoke** can be used.
- **viPeek/viPoke** calls do not return status codes.

- Only one active **viMapAddress** is allowed per *vi* session.
- There may be a limit to the number of simultaneous active **viMapAddress** calls per process or system.

Using High-Level **viIn/viOut**

High-level **viIn/viOut** calls are best in situations where a few widely scattered memory accesses are required and speed is not a major consideration.

The advantages of high-level **viIn/viOut** are:

- It is the simplest method to implement.
- There is no limit on the number of active maps.
- A16, A24, and A32 memory access can be mixed in a single *vi* session.

The disadvantage of high-level **viIn/viOut** calls is that they are slower than **viPeek/viPoke**.

Using High-Level **viMoveIn/viMoveOut**

High-level **viMoveIn/viMoveOut** calls provide the highest possible performance for transferring blocks of data to or from the VXI backplane. Although these calls have higher initial overhead than the **viPeek/viPoke** calls, they are optimized on each platform to provide the fastest possible transfer rate for large blocks of data.

For small blocks, the overhead associated with **viMoveIn/viMoveOut** may actually make these calls longer than an equivalent loop of **viIn/viOut** calls. The block size at which **viMoveIn/viMoveOut** becomes faster depends on the particular platform and processor speed.

The advantages of high-level **viMoveIn/viMoveOut** are:

- They are simple to use.
- There is no limit on number of active maps.
- A16, A24, and A32 memory access can be mixed in a single *vi* session.
- They provide the best performance when transferring large blocks of data.
- They support both block and FIFO mode.

The disadvantage of **viMoveIn/viMoveOut** calls is that they have higher initial overhead than **viPeek/viPoke**.

Sample: Using VXI Memory I/O

This program demonstrates using various types of VXI memory I/O.

```
/* memio.c
This example program demonstrates the use of
various memory I/O methods in VISA. */

#include <visa.h>
#include <stdlib.h>
#include <stdio.h>

#define VXI_INST "VXI0::24::INSTR"

void main () {
    ViSession defaultRM, vi;
    ViAddr          address;
    ViUInt16        accessMode;
    unsigned short *memPtr16;
    unsigned short id_reg;
    unsigned short devtype_reg;
    unsigned short memArray[2];

    /*Open default resource manager and session
    to instr*/
    viOpenDefaultRM (&defaultRM);
    viOpen defaultRM, VXI_INST, VI_NULL,VI_NULL,
    &vi);

    /*
=====
==
    Low level memory I/O = viPeek16 = direct
    memory dereference (when allowed)

=====
*/
    /* Map into memory space */
    viMapAddress (vi, VI_A16_SPACE, 0x00, 0x10,
VI_FALSE,VI_NULL, &address);
```

```

/*
=====
=
    Using viPeek
=====
*/
    Read instrument id register contents */
    viPeek16 (vi, address, &id_reg);

    /* Read device type register contents
    ViAddr is defined as a (void *) so we must
    cast it to something else in order to do
    pointer arithmetic. */

    viPeek16 (vi, (ViAddr)((ViUInt16 *)address +
    0x01), &devtype_reg);

    /* Print results */
    printf ("    viPeek16: ID Register = 0x%4X\n",
    id_reg);
    printf ("    viPeek16: Device Type Register =
    0x%4X\n", devtype_reg);

    /* Use direct memory dereferencing if
    supported */
    viGetAttribute( vi, VI_ATTR_WIN_ACCESS,
    &accessMode );
    if ( accessMode == VI_DEREF_ADDR ) {

        /* assign pointer to variable of correct
        type */
        memPtr16 = (unsigned short *)address;

        /* do the actual memory reads */
        id_reg = *memPtr16;
        devtype_reg = *(memPtr16+1);

        /* Print results */
        printf ("dereference: ID Register =
        0x%4X\n", id_reg);
        printf ("dereference: Device Type Register
        =0x%4X\n", devtype_reg);
    }

```

4 Programming via GPIB and VXI

```
/* Unmap memory space */
viUnmapAddress (vi);

/*=====
High Level memory I/O = viIn16
=====*/
/* Read instrument id register contents */
viIn16 (vi, VI_A16_SPACE, 0x00, &id_reg);

/* Read device type register contents */
viIn16 (vi, VI_A16_SPACE, 0x02,&devtype_reg);

/* Print results */
printf (" viIn16: ID Register = 0x%4X\n",
id_reg);
printf (" viIn16: Device Type Register =
0x%4X\n", devtype_reg);

/*=====
=====
High Level block memory I/O = viMoveIn16

The viMoveIn/viMoveOut commands do both block
read/write and FIFO read write. These commands
offer the best performance for reading and
writing large data blocks on the VXI backplane.
For this example we are only moving 2 words at a
time. Normally, these functions would be used to
move much larger blocks of data.

If the value of VI_ATTR_SRC_INCREMENT is 1 (the
default),viMoveIn does a block read. If the
value of VI_ATTR_SRC_INCREMENT is 0, viMoveIn
does a FIFO read.

If the value of VI_ATTR_DEST_INCREMENT is 1 (the
default),viMoveOut does a block write. If the
value of VI_ATTR_DEST_INCREMENT is 0, viMoveOut
does a FIFO write.
===== */
```

```

/* Demonstrate block read.
   Read instrument id register and device type
   register into an array.*/

viMoveIn16 (vi, VI_A16_SPACE, 0x00, 2,
memArray);

/* Print results */
printf (" viMoveIn16: ID Register = 0x%4X\n",
        memArray[0]);
printf (" viMoveIn16: Device Type Register =
        0x%4X\n", memArray[1]);

/* Demonstrate FIFO read.

   First set the source increment to 0 so we will
   repetitively read from the same memory
   location.*/
viSetAttribute( vi, VI_ATTR_SRC_INCREMENT, 0
);

/* Do a FIFO read of the Id Register */
viMoveIn16 (vi, VI_A16_SPACE, 0x00, 2,
memArray);

/* Print results */
printf (" viMoveIn16: 1 ID Register =
0x%4X\n",
        memArray[0]);
printf (" viMoveIn16: 2 ID Register =
0x%4X\n",
        memArray[1]);

/* Close sessions */
viClose (vi);
viClose (defaultRM); }

```

Using the Memory Access Resource

For VISA 1.1 and later, the Memory Access (MEMACC) resource type has been added to VXI and GPIB-VXI. VXI::MEMACC and GPIB-VXI::MEMACC allow access to all of the A16, A24, and A32 memory by providing the controller with access to arbitrary registers or memory addresses on memory-mapped buses.

The MEMACC resource, like any other resource, starts with the basic operations and attributes of other VISA resources. For example, modifying the state of an attribute is done via the operation **viSetAttribute** (see *VISA Resource Classes* in the *VISA Online Help* for details).

Memory I/O Services

Memory I/O services include high-level memory I/O services and low-level memory I/O services.

High-Level Memory I/O Services

High-level memory I/O services allow register-level access to the interfaces that support direct memory access, such as the VXIbus, VMEbus, MXIbus, or even VME or VXI memory through a system controlled by a GPIB-VXI controller. A resource exists for each interface to which the controller has access.

You can access memory on the interface bus through operations such as **viIn16** and **viOut16**. These operations encapsulate the map/unmap and peek/poke operations found in the low-level service. There is no need to explicitly map the memory to a window.

Low-Level Memory I/O Services

Low-level memory I/O services also allow register-level access to the interfaces that support direct memory access. Before an application can use the low-level service on the interface bus, it must map a range of addresses using the operation **viMapAddress**.

Although the resource handles the allocation and operation of the window, the programmer must free the window via **viUnMapAddress** when finished. This makes the window available for the system to reallocate.

Sample: MEMACC Resource Program

This program demonstrates one way to use the MEMACC resource to open the entire VXI A16 memory and then calculate an offset to address a specific device.

```

/* peek16.c */
#include <stdio.h>
#include <stdlib.h>
#include <visa.h>

#define EXIT1
#define NO_EXIT 0

/* This function simplifies checking for VISA
errors. */
void checkError( ViSession vi, ViStatus status,
char
    *errStr, int doexit){
    char buf[256];
    if (status >= VI_SUCCESS)
        return;
    buf[0] = 0;
    viStatusDesc( vi, status, buf );
    printf( "ERROR 0x%lx (%s)\n '%s'\n", status,
errStr,
        buf );
    if ( doexit == EXIT )
        exit ( 1 );
}

void main() {
    ViSession drm;
    ViSession vi;
    ViUInt16inData16 = 0;
    ViUInt16peekData16 = 0;
    ViUInt8*addr;

```

4 Programming via GPIB and VXI

```
ViUInt16*addr16;
ViStatusstatus;
ViUInt16offset;

status = viOpenDefaultRM ( &drm );
checkError( 0, status, "viOpenDefaultRM",
EXIT );

/* Open a session to the VXI MEMACC Resource*/
status = viOpen( drm, "vxi0::memacc",
VI_NULL, VI_NULL,
&vi );
checkError ( 0, status, "viOpen", EXIT );

/* Calculate the A16 offset of the VXI
REgisters for
the device at VXI logical address 8. */
offset = 0xc000 + 64 * 8;

/* Open a map to all of A16 memory space. */
status =
viMapAddress(vi,VI_A16_SPACE,0,0x10000,
VI_FALSE,0,(ViPAddr)(&addr));
checkError( vi, status, "viMapAddress", EXIT
);

/* Offset the address pointer returned from
viMapAddress for use with viPeek16. */
addr16 = (ViUInt16 *) (addr + offset);

/* Peek the contents of the card's ID register
(offset
0 from card's base address. Note that
viPeek does
not return a status code. */
viPeek16( vi, addr16, &peekData16 );

/* Now use viIn16 and read the contents of the
same
register */
status = viIn16(vi, VI_A16_SPACE,
ViBusAddress)offset, &inData16 );
checkError(vi, status, "viIn16", NO_EXIT );
```



```

/* Print the results. */
printf( "inData16 : 0x%04hx\n", inData16 );
printf( "peekData16: 0x%04hx\n", peekData16
);

viClose( vi );
viClose (drm );
}

```

MEMACC Attribute Descriptions

Generic MEMACC Attributes

The following read-only attributes (VI_ATTR_TMO_VALUE is read/write) provide general interface information.

Table 27 Attributes That Provide General Interface Information

Attribute	Description
VI_ATTR_INTF_TYPE	Interface type of the given session.
VI_ATTR_INTF_NUM	Board number for the given interface.
VI_ATTR_TMO_VALUE	Minimum timeout value to use, in milliseconds. A timeout value of VI_TMO_IMMEDIATE means operation should never wait for the device to respond. A timeout value of VI_TMO_INFINITE disables the timeout mechanism.
VI_ATTR_INTF_INST_NAME	Human-readable text describing the given interface.
VI_ATTR_DMA_ALLOW_EN	Specifies whether I/O accesses should use DMA (VI_TRUE) or Programmed I/O (VI_FALSE).

VXI and GPIB-VXI Specific MEMACC Attributes

The following attributes, most of which are read/write, provide memory window control information.

Table 28 Attributes That Provide Memory Window Control Information

Attribute	Description
VI_ATTR_VXI_LA	Logical address of the local controller.
VI_ATTR_SRC_INCREMENT	Used in viMoveInxx operation to specify how much the source offset is to be incremented after every transfer. The default value is 1 and the viMoveInxx operation moves from consecutive elements. If this attribute is set to 0, the viMoveInxx operation will always read from the same element, essentially treating the source as a FIFO register.
VI_ATTR_DEST_INCREMENT	Used in viMoveOutxx operation to specify how much the destination offset is to be incremented after every transfer. The default value is 1 and the viMoveOutxx operation moves into consecutive elements. If this attribute is set to 0, the viMoveOutxx operation will always write to the same element, essentially treating the destination as a FIFO register.
VI_ATTR_WIN_ACCESS	Specifies modes in which the current window may be addressed: not currently mapped, through the viPeekxx or viPokexx operations only, or through operations and/or by directly de-referencing the address parameter as a pointer.
VI_ATTR_WIN_BASE_ADDR	Base address of the interface bus to which this window is mapped.
VI_ATTR_WIN_SIZE	Size of the region mapped to this window.

Table 28 Attributes That Provide Memory Window Control Information

VI_ATTR_SRC_BYTE_ORDER	Specifies the byte order used in high-level access operations, such as viInxx and viMoveInxx , when reading from the source.
VI_ATTR_DEST_BYTE_ORDER	Specifies the byte order used in high level access operations, such as viOutxx and viMoveOutxx , when writing to the destination.
VI_ATTR_WIN_BYTE_ORDER	Specifies the byte order used in low-level access operations, such as viMapAddress , viPeekxx , and viPokexx , when accessing the mapped window.
VI_ATTR_SRC_ACCESS_PRIV	Specifies the address modifier used in high-level access operations, such as viInxx and viMoveInxx , when reading from the source.
VI_ATTR_DEST_ACCESS_PRIV	Specifies the address modifier used in high-level access operations such as viOutxx and viMoveOutxx , when writing to destination.
VI_ATTR_WIN_ACCESS_PRIV	Specifies the address modifier used in low-level access operations, such as viMapAddress , viPeekxx , and viPokexx , when accessing the mapped window.

GPIB-VXI Specific MEMACC Attributes

The following read-only attributes provide specific address information about GPIB hardware.

Table 29 Attributes that Provide Specific Address Information

Attribute	Description
VI_ATTR_INTF_PARENT_NUM	Board number of the GPIB board to which the GPIB-VXI is attached.

Table 29 Attributes that Provide Specific Address Information

VI_ATTR_GPIB_PRIMARY_ADDR	Primary address of the GPIB-VXI controller used by the session.
VI_ATTR_GPIB_SECONDARY_ADDR	Secondary address of the GPIB-VXI controller used by the session.

MEMACC Resource Event Attribute

The following read-only events provide notification that an asynchronous operation has completed.

Table 30 Events Providing Notification About Asynchronous Operations

Attribute	Description
VI_ATTR_EVENT_TYPE	Unique logical identifier of the event.
VI_ATTR_STATUS	Return code of the asynchronous I/O operation that has completed.
VI_ATTR_JOB_ID	Job ID of the asynchronous I/O operation that has completed.
VI_ATTR_BUFFER	Address of a buffer used in an asynchronous operation.
VI_ATTR_RET_COUNT	Actual number of elements that were asynchronously transferred.

Using VXI-Specific Attributes

VXI-specific attributes can be useful to determine the state of your VXI system. Attributes are read-only and read/write. Read-only attributes specify things such as the logical address of the VXI device and information about where your VXI device is mapped. This section shows how you might use some of the VXI-specific attributes. See *VISA Resource Classes* in the *VISA Online Help* for information on VISA attributes.

Using the Map Address as a Pointer

The `VI_ATTR_WIN_ACCESS` read-only attribute specifies how a window can be accessed. You can access a mapped window with the VISA low-level memory functions or with a C pointer if the address is de-referenced. To determine how to access the window, read the `VI_ATTR_WIN_ACCESS` attribute.

`VI_ATTR_WIN_ACCESS` Settings

The `VI_ATTR_WIN_ACCESS` read-only attribute can be set to one of the following:

Table 31 Settings for the `VI_ATTR_WIN_ACCESS` Attribute

Setting	Description
<code>VI_NMAPPED</code>	Specifies that the window is not mapped.
<code>VI_USE_OPERS</code>	Specifies that the window is mapped and you can only use the low-level memory functions to access the data.
<code>VI_DEREF_AD DR</code>	Specifies that the window is mapped and has a de-referenced address. In this case you can use the low-level memory functions to access the data, or you can use a C pointer. Using a de-referenced C pointer will allow faster access to data.

Sample: Determining Window Mapping

```
ViAddr address;
Vi UInt16 access;
ViUInt16 value;
.
.
.

viMapAddress(vi, VI_A16_SPACE, 0x00, 0x04,
VI_FALSE,
    VI_NULL, &address);
viGetAttribute(vi, VI_ATTR_WIN_ACCESS, &access);
.
.
If(access==VI_USE_OPERS) {
    viPeek16(vi, (ViAddr)((ViUInt16 *)address) +
        4/sizeof(ViUInt16)), &value)
}else if (access==VI_DEREF_ADDR){
    value=*((ViUInt16
*)address+4/sizeof(ViUInt16));
}else if (access==VI_NMAPPED){
    return error;
}
.
.
```

Setting the VXI Trigger Line

The VI_ATTR_TRIG_ID attribute is used to set the VXI trigger line. This attribute is listed under generic attributes and defaults to VI_TRIG_SW (software trigger). To set one of the VXI trigger lines, set the VI_ATTR_TRIG_ID attribute as follows:

```
viSetAttribute(vi, VI_ATTR_TRIG_ID,
VI_TRIG_TTL0);
```

The above function sets the VXI trigger line to TTL trigger line 0 (VI_TRIG_TTL0). The following are valid VXI trigger lines. (Panel In is an Agilent extension of the VISA specification.)

Table 32 VXI Trigger Lines and Values

VXI Trigger Line	VI_ATTR_TRIG_ID Value
TTL 0	VI_TRIG_TTL0
TTL 1	VI_TRIG_TTL1
TTL 2	VI_TRIG_TTL2
TTL 3	VI_TRIG_TTL3
TTL 4	VI_TRIG_TTL4
TTL 5	VI_TRIG_TTL5
TTL 6	VI_TRIG_TTL6
TTL 7	VI_TRIG_TTL7
ECL 0	VI_TRIG_ECL0
ECL 1	VI_TRIG_ECL1
Panel In	VI_TRIG_PANEL_IN

Once you set a VXI trigger line, you can set up an event handler to be called when the trigger line fires. See “Using Events and Handlers” on page 56 for more information on setting up an event handler. Once the VI_EVENT_TRIG event is enabled, the VI_ATTR_TRIG_ID becomes a read only attribute and cannot be changed. You must set this attribute prior to enabling event triggers.

The VI_ATTR_TRIG_ID attribute can also be used by **viAssertTrigger** function to assert software or hardware triggers. If VI_ATTR_TRIG_ID is VI_TRIG_SW, the device is sent a Word Serial Trigger command. If the attribute is any other value, a hardware trigger is sent on the line corresponding to the value of that attribute.

4 Programming via GPIB and VXI



5 Programming via LAN

This chapter provides guidelines for programming via a LAN (Local Area Network). A LAN allows you to extend the control of instrumentation beyond the limits of typical instrument interfaces.

The chapter contents are:

- LAN Interfaces Overview
- Communicating with LAN-Connected Devices

NOTE

This chapter describes programming using the VISA TCPIP interface type to communicate directly with a LAN-connected device, as well as using a remote interface (also known as a LAN client) to emulate a GPIB, serial (ASRL), or USB interface on the local machine to communicate with a LAN-connected device.

See the *Agilent IO Libraries Suite Online Help* for information on how to start and stop the Remote IO Server software, and on how to create and configure LAN interfaces and remote GPIB/USB/serial interfaces.

See the *Connectivity Guide* for detailed information on connecting instruments to a LAN, and for a discussion of network protocols.



LAN and Remote Interfaces Overview

This section provides an overview of LAN (Local Area Network) interfaces. A LAN is a way to extend the control of instrumentation beyond the limits of typical instrument interfaces. To communicate with instruments over the LAN, you must first configure a LAN interface or a remote GPIB, USB, or serial interface, using the Agilent Connection Expert.

Direct LAN Connection versus Remote IO Server/Client Connection

Some instruments support direct connection to the LAN. These instruments include an RJ-45 or other standard LAN connector and software support for operating as an independent device on the network. Some of these instruments are Web-enabled, meaning that they host a Web page which you can access over the LAN.

With the Agilent IO Libraries Suite, you can connect to instruments across the LAN even if they do not have direct LAN capability, if they are connected to gateways (such as the Agilent E5810A) or to another PC running the Remote IO Server software.

Refer to the *IO Libraries Suite* and the *Connectivity Guide* for information on connecting and configuring different types of LAN instrument connections.

Remote IO Server/Client Architecture

The Remote IO Server and Client software provided with Agilent IO Libraries Suite allows instrumentation to be controlled over a LAN. Using standard LAN connections, instruments can be controlled from computers that do not have special interfaces for instrument control.

Client/Server Model

The IO Libraries Suite software uses the **client/server** model of computing. Client/server computing refers to a model in which an application (the **client**) does not perform all necessary tasks of the application itself. Instead, the client makes requests of another computing device (the **remote I/O server**) for certain services.

As shown in the following figure, a remote I/O client (a Windows PC) makes VISA requests over the network to a remote I/O server (such as a Windows PC, an E5810 LAN/GPIB Gateway, or a Series 700 HP-UX workstation).

Gateway Operation

The remote I/O server is connected to the instrumentation or devices to be controlled. Once the remote I/O server has completed the requested operation on the instrument or device, the remote I/O server sends a reply to the client. This reply contains the requested data and status information that indicates whether or not the operation was successful. The remote I/O server acts as a **gateway** between the LAN software that the client system supports and the instrument-specific interface that the device supports.

5 Programming via LAN

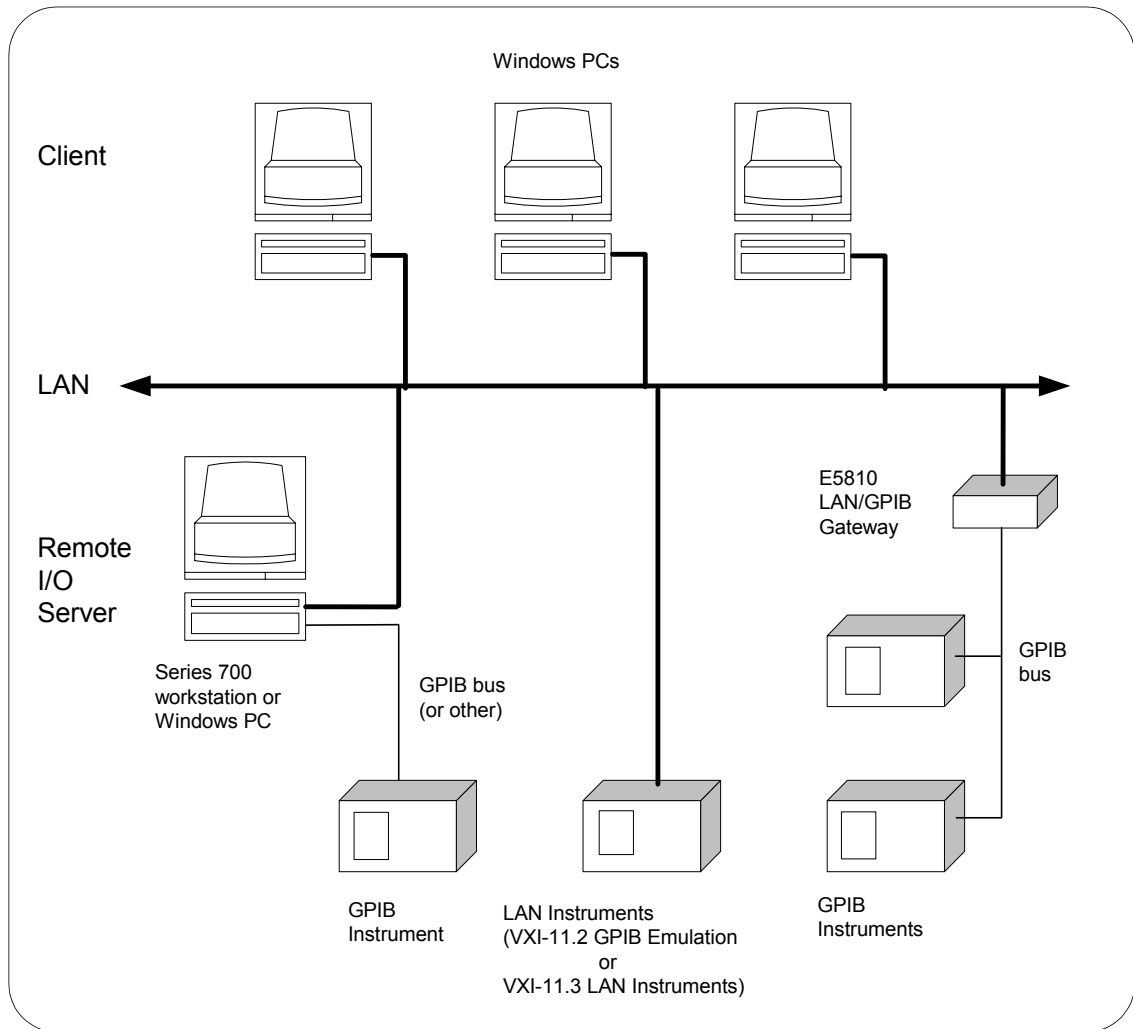

Addressing LAN-Connected Devices

VISA can communicate with LAN-connected devices in one of two ways:

- TCPIP interface type
- Remote interface type (available only with Agilent IO Libraries Suite)

Using the TCPIP Interface Type for LAN Access

VISA provides the TCPIP interface type to communicate with LAN-connected devices. These can be devices connected directly to the LAN, or they can be connected to the LAN through a LAN gateway such as the Agilent E5810 LAN/GPIB gateway or through Remote IO Server software running on a remote computer with instruments connected to it.

The format of a TCPIP VISA resource string is:

```
TCPIP[<board>]::<hostname>[::<LAN device name>][::INSTR]
```

where:

- <board> = board number (default is 0)
- <hostname> = the hostname or IP address of the LAN device or server
- <LAN device name> = the remote device name (case sensitive with default name of **inst0**)

Using Connection Expert, you can configure a LAN interface to use either the **VXI-11 protocol** or the **SICL-LAN** protocol. The protocol(s) you will use depends upon the devices you are using and the protocol(s) that they support.

The VXI-11 protocol constrains the LAN device name to be of the form **inst0**, **inst1**, ... for VXI-11.3 devices and **gpib0,n**, **gpib1,n**, ... for VXI-11.2 (GPIB Emulation) devices.

The SICL-LAN protocol allows any valid SICL name for the LAN device name. A valid SICL name must be a unique string of alphanumeric characters, starting with a letter.

5 Programming via LAN

Some examples of TCPIP resource strings follow.

Table 33 Example TCPIP Resource Strings

String	Description
TCPIP0::testMachine@agilent.com::gpib0,2::INSTR	A VXI-11.2 GPIB device at hostname testMachine@agilent.com .
TCPIP0::123.456.0.21::gpib0,2::INSTR	A VXI-11.2 GPIB device at a machine whose IP address is 123.456.0.21.
TCPIP0::myMachine::inst0::INSTR	A VXI-11.3 LAN instrument at hostname myMachine .
TCPIP::myMachine	A VXI-11.3 LAN instrument at hostname myMachine . Note that default values for board = 0 , LAN device name = inst0 , and the ::INSTR resource class are used.
TCPIP0::testMachine1::COM1,488::INSTR	An RS-232 device connected to a LAN server or gateway at hostname testMachine1 . This device must use SICL-LAN protocol since RS-232 devices are not supported by the VXI-11 protocol.
TCPIP0::myMachine::gpib0,2::INSTR	A GPIB device at hostname myMachine . This device must use SICL-LAN protocol since gpib0,2 is not a valid remote name with the VXI-11 protocol.
TCPIP0::myMachine::UsbDevice1::INSTR	A USB device with a SICL alias of UsbDevice1 connected to a LAN server at hostname myMachine . Note that the SICL alias is defined on the remote machine, not on the local machine. <i>Although the SICL and VISA alias names are normally the same, if they are not, you must be sure to use the SICL alias and not the VISA alias.</i> This device must use the SICL-LAN protocol since USB devices are not supported by the VXI-11 protocol.

Table 33 Example TCPIP Resource Strings

String	Description
TCPIP0::myMachine::usb0[2391::1031::SN_00123 ::0]::INSTR	<p>A USB device with:</p> <p>Manufacture ID = 2391 Model Code = 1031 Serial Number = 'SN_00123' USBTMC Intfc # = 0</p> <p>connected to a LAN server at hostname myMachine.</p> <p>This device must use SICL-LAN protocol since USB devices are not supported by the VXI-11 protocol.</p>

NOTE

A LAN session to a remote interface provides the same VISA function support as if the interface were local, except that VXI-specific functions are not supported over LAN.

Addressing a Session Using the TCPIP Interface Type

This sample shows one way to open a device session with a GPIB device at primary address 23 on a remote PC that is running a LAN server. The hostname of the remote PC is **myMachine**. See Chapter 3, “Programming with VISA”, for more information on addressing device sessions.

```
ViSession defaultRM, vi;.
.
viOpenDefaultRM(&defaultRM);
viOpen(defaultRM,
"TCPIP0::myMachine::gpib0,23::INSTR", VI_NULL,
VI_NULL, &vi);
.
.
viClose(vi);
```

```
viClose(defaultRM);
```

Using a Remote Interface for LAN Access

Agilent VISA provides three types of VISA LAN Client interfaces, implemented in Agilent IO Libraries Suite as **remote interfaces**:

- Remote serial interface (ASRL VISA LAN Client)
- Remote GPIB interface (GPIB VISA LAN Client)
- Remote USB interface (USB VISA LAN Client)

Remote interfaces are configured using Connection Expert; they provide virtual GPIB, serial, or USB interfaces. They make it possible to remotely access a LAN-connected device as if it were connected to a local interface. If, for example, the **GPIB2** interface is configured as a remote GPIB interface, a program controlling the devices **GPIB2::5::INSTR** and **GPIB2::7::INSTR** would not be aware of the fact that these devices are actually connected via LAN and not to a GPIB interface connected to the local machine.

See the *Agilent IO Libraries Suite Online Help* for specific information on configuring remote interfaces.

Remote Serial Interface (ASRL VISA LAN Client)

A remote serial interface can use only the SICL-LAN protocol. A remote serial interface can be configured to use the serial port on the Agilent E5810 LAN/GPIB gateway or the serial ports on a PC running the Remote IO Server software.

Remote GPIB Interface (GPIB VISA LAN Client)

A remote GPIB interface can use both the VXI-11 and SICL-LAN protocols. Typical uses for remote GPIB interfaces are with LAN/GPIB gateways (e.g. Agilent E5810), PCs with GPIB interfaces that are running a LAN server, and VXI-11.2 LAN-based instruments.

A remote GPIB interface can only be used to communicate with VXI-11.2 (GPIB Emulation) devices. This is because the VISA GPIB interface type requires a primary and (optionally) a secondary address when communicating with a device. VXI-11.3 devices do not support the concept of a primary address, so they cannot be accessed with a remote GPIB interface.

Remote USB Interface (USB VISA LAN Client)

A remote USB interface can use only the SICL-LAN protocol. It can communicate with USB devices attached to a remote PC running the Remote IO Server software.

Note that if you have defined a VISA alias for a USB device on the remote I/O server, you must either define the same (or another) alias for the remote USB device on the client PC, or use the full USB resource string. Alias definitions are not shared between the remote I/O server and the client.

Addressing a Session Using a Remote Interface

In general, the rules to address a remote session are the same as to address a local session. The only difference for a remote session is that you use the VISA interface ID (provided during I/O configuration via Connection Expert) that relates to the remote interface.

The following sample shows one way to open a device session with a GPIB device at primary address 23 on a remote PC that is running Remote IO Server software. A remote GPIB interface has been configured at GPIB2 to communicate with that machine. See Chapter 3, “Programming with VISA”, for more information on addressing device sessions.

```
ViSession defaultRM, vi;.
.
viOpenDefaultRM(&defaultRM);
viOpen(defaultRM, "GPIB2::23::INSTR", VI_NULL,
VI_NULL, &vi);
.
.
viClose(vi);
viClose(defaultRM);
```

5 Programming via LAN



6 Programming via USB

This chapter provides guidelines for VISA programming of USB instruments that conform to USBTMC (Universal Serial Bus Test and Measurement Class) and/or USBTMC-USB488 (Universal Serial Bus Test and Measurement Class, Subclass USB488 Specification).

The chapter contents are:

- USB Interfaces Overview
- Communicating with a USB Instrument Using VISA



USB Interfaces Overview

USBTMC/USBTMC-USB488 instruments are detected and automatically configured by Agilent VISA when they are plugged into the computer. The *Agilent IO Libraries Suite Online Help* describes the USB instrument configuration process in more detail.

NOTE

Do not confuse the Agilent 82357 USB/GPIB Interface with a USBTMC device. The 82357 is automatically configured as a GPIB interface, not as a USBTMC device, when it is plugged into the computer. Only USBTMC/USBTMC-USB488 devices are configured as USB devices by Agilent VISA.

Due to the complexity of the VISA USB resource string, a **VISA alias** (simple name) is assigned to each USB instrument when it is plugged into the computer. You can use either the alias or the full VISA resource string when opening a VISA resource, but using the alias is recommended because it is simpler and because it allows substitution of USB instruments without the need to change the VISA program.

You can also create VISA aliases for other (non-USB) instruments, using the Agilent Connection Expert.

Communicating with a USB Instrument Using VISA

To establish communications with a USB device using VISA, you can either use the full VISA resource string for the device or use the alias provided by VISA. Using the alias is recommended, for reasons described below.

Using the full VISA resource string, a **viOpen** call would look something like this:

```
viOpen ( . . . ,
"USB0::2391::1031::0000000123::0::INSTR", . . .
);
```

Following is a summary of the components of this call.

Table 34 Summary of Full-String viOpen Call

Value	Description	Data Type
2391	Manufacturer ID	16-bit unsigned integer
1031	Model Code	16-bit unsigned integer
0000000123	Serial Number	string value
0	USBTMC Interface Number	8-bit unsigned integer

This string uniquely identifies the USB device. The values needed for the resource string are displayed in a dialog box when the device is plugged into the computer.

To simplify the way a USB device is identified, Agilent VISA also provides an alias which can be used in place of this resource string. The first USB device that is plugged in is assigned a default alias of **UsbDevice1**. Additional devices are assigned aliases of **UsbDevice2**, **UsbDevice3**, etc. You can modify the default alias name at the time a device is plugged in, or by running Agilent Connection Expert and changing the properties of the VISA alias.

Although the case of a VISA alias is preserved, case is ignored when the alias is used in place of the full resource string in a **viOpen** call. For example, `UsbDevice1`, `usbdevice1` and `USBDEVICE1` all refer to the same device.

Using the alias, a **viOpen** call would look something like this:

```
viOpen( . . ., "UsbDevice1", . . . );
```

As you can see, this is much simpler than having to use the full resource string for a USB device.

Using the alias in a program also makes it more portable. For example, two identical USB function generators have different resource strings because they have different serial numbers. If these function generators are used in two different test systems and you use the full resource string to access the function generator in the test program, you cannot use that same program for both test systems, since the function generators' full resource strings are different. By using the alias in the program, however, you can use the same program in both test systems. All you need to do is make sure the same alias is used for the function generator in both systems.



Glossary

access board

The GPIB interface to which a particular device is connected.

Active Controller

See "Controller in Charge".

address

A string (or other language construct) that uniquely locates and identifies a resource. VISA defines an ASCII-based grammar that associates address strings with particular physical devices or interfaces and VISA resources.

Agilent 488

An I/O library provided in Agilent IO Libraries Suite for compatibility with existing test & measurement programs that were developed using National Instruments' NI-488 or other similar libraries. Agilent 488 supports communication with GPIB devices and interfaces, but does not support USB, LAN, RS-232, or VXI communications.

alias

See **VISA alias**.

API

Application Programming Interface. The interface that a programmer sees when creating an application. For example, the VISA API consists of the sum of all of the operations, attributes, and events of each of the VISA ResourceClasses.



attribute

In VISA and SICL, a value that indicates the operational state of a resource. Some attributes can be changed; others are read-only.

board

A GPIB interface. It may be a physical board, an adapter (such as the 82357 USB/GPIB adapter), or a remote GPIB interface.

board descriptor

A handle, returned from `ibfind`, that uniquely identifies a GPIB interface (board) in Agilent 488 original API calls. Also called an interface descriptor or board unit descriptor.

board-level

Refers to Agilent 488 functions that operate on an interface (board), rather than on a device.

bus error

An error that signals failure to access an address. Bus errors occur in conjunction with low-level accesses to memory, and usually involve hardware with bus mapping capabilities. Bus errors may be caused by non-existent memory, a non-existent register, an incorrect device access, etc.

bus error handler

Software that runs when a bus error occurs.

CIC

Controller in Charge.

command bytes

GPIB commands encoded as individual bytes. Also called **GPIB commands** or **interface messages**.

commander

In test-system architectures, a device that has the ability to control another device. In a specialized case, a commander may also be the device that has sole control over another device (as with the VXI Commander/Servant hierarchy).

commander session

A session that communicates to the interface's commander. Commander sessions are used when an interface is in a non-Controller role.

communication channel

A communication path between a software element and a resource. In VISA, "communication channel" is synonymous with "session." Every communication channel in VISA is unique.

Connection Expert

An Agilent software utility that helps you quickly establish connections between your instruments and your PC. It also helps you troubleshoot connectivity problems. Connection Expert is part of the Agilent IO Libraries Suite product.

Controller

A device (typically a computer) used to communicate with another device or devices (typically instruments). The Controller is in charge of communications and device operation; it controls the flow of communication and performs addressing and other bus management functions.

Controller in Charge

The device currently in control of the GPIB.

device

A unit that receives commands from a Controller. A device is typically an instrument, but can also be a computer acting in a non-Controller role or another peripheral such as a printer or plotter. In VISA, a device is logically represented by the association of several VISA resources.

device descriptor

A handle, returned from **ibdev** or **ibfind**, that uniquely identifies a device in Agilent 488 original API calls. Also called a **device unit descriptor**.

device driver

Software code that communicates with a device: for example, a printer driver that communicates with a printer from a PC. A device driver may either communicate directly with a device by reading to and writing from registers, or it may communicate through an interface driver.

device session

A session that communicates as a Controller with a single, specific device such as an instrument.

device-level

Refers to Agilent 488 functions that operate on a device (instrument), rather than on an interface.

direct I/O

Programmatic communication with instruments not involving an instrument driver. Direct I/O may be accomplished by using an IO Library (VISA, VISA COM, SICL, or Agilent 488) or by using direct I/O tools such as those provided by Agilent VEE and Agilent T&M Toolkit.

driver

See **instrument driver** and **device driver**.

explorer view

The tree view within the Connection Expert window that shows all devices connected to a test system.

handler

A software routine that responds to an asynchronous event such as an SRQ or an interrupt.

instrument

A device that accepts commands and performs a test and measurement function.

instrument driver

Software that runs on a computer to allow an application to control a particular instrument.

Interactive IO

An Agilent application that allows you to interactively send commands to instruments and read the results. Interactive IO is part of the Agilent IO Libraries Suite product.

interface

A connection and medium of communication between devices and controllers. Interfaces include mechanical, electrical, and protocol connections.

interface descriptor

A handle, returned from **ibfind**, that uniquely identifies a GPIB interface (board) in Agilent 488 original API calls. Also called a **board descriptor** or **board unit descriptor**.

interface driver

Software that communicates with an interface. The interface driver also handles commands used to perform communications on an interface.

interface messages

GPIB commands encoded as individual bytes. Also called **GPIB commands** or **command bytes**.

interface session

A session that communicates and controls parameters affecting an entire interface.

interrupt

An asynchronous event that requires attention and actions that are out of the normal flow of control of a program.

IO Control

The icon in the Windows notification area (usually the lower right corner of your screen). The IO Control gives you access to Agilent I/O utilities such as Connection Expert, Agilent I/O documentation, and VISA options.

IO Libraries

Application programming interfaces (APIs) for direct I/O communication between applications and devices. There are four Agilent IO Libraries in the Agilent IO Libraries Suite: VISA, VISA COM, SICL, and Agilent 488.

Listener

A device that can receive data from the bus when instructed (addressed to listen) by the System Controller.

lock

A state that prohibits other users from accessing a resource such as a device or interface.

logical unit

A number associated with an interface. A logical unit, in SICL and Agilent VEE, uniquely identifies an interface. Each interface on the controller must have a unique logical unit.

mapping

An operation that returns a reference to a specified section of an address space and makes the specified range of addresses accessible to the requester. This function is independent of memory allocation.

non-Controller role

A computer is in a non-Controller role when it acts as a device communicating with a computer that is in a Controller role.

notification area

The area on the Windows taskbar where notifications are posted, typically in the lower right corner of the screen. Also called **taskbar notification area** or **Windows notification area**.

operation

A defined action that can be performed on a resource.

primary VISA

The VISA installation that controls the visa32.dll file. The primary VISA will be used by default in VISA applications. See also **secondary VISA**.

process

An operating system component that shares a system's resources. A single-process computer system allows only a single program to execute at any given time. A multi-process computer system allows multiple programs to execute simultaneously, each in a separate process environment.

programming alias

See **VISA alias**.

refresh

In Connection Expert, the action that invokes the discovery mechanism for detecting interfaces and instruments connected to your computer. The explorer view is then refreshed to show the current, discovered state of your test system.

register

An address location that contains a value that represents the state of hardware, or that can be written into to cause hardware to perform a specified action or to enter a specified state.

resource (or resource instance)

In VISA, an implementation of a resource class (in object-oriented terms, an instance of a resource class). For example, an instrument is represented by a resource instance.

resource class

The definition of a particular resource type (a class in object-oriented terms). For example, the VISA Instrument Control resource classes define how to create a resource to control a particular capability of a device.

resource descriptor

A string, such as a VISA resource descriptor, that specifies the I/O address of a device.

SCPI

Standard Commands for Programmable Instrumentation: a standard set of commands, defined by the SCPI Consortium, to control programmable test and measurement devices in instrumentation systems.

secondary VISA

A VISA installation that does not install visa32.dll in the standard VISA location. The secondary VISA installation names its VISA DLL with a different name (agvisa32.dll) so that it can be accessed programmatically. The primary VISA will be used by default in VISA applications. See also **primary VISA**.

session

VISA term for a communication channel. An instance of a communications path between a software element and a resource. Every communication channel in VISA is unique.

SICL

Standard Instrument Control Library. SICL is an Agilent-defined API for instrument I/O. Agilent SICL is one of the IO Libraries installed with Agilent IO Libraries Suite.

side-by-side

A side-by-side installation allows two vendors' implementations of VISA to be used on the same computer. See also **primary VISA** and **secondary VISA**.

SRQ

An IEEE-488 Service Request. This is an asynchronous request (an interrupt) from a remote device that requires service. In GPIB, an SRQ is implemented by asserting the SRQ line on the GPIB. In VXI, an SRQ is implemented by sending the Request for Service True event (REQT).

Standby Controller

A device or interface that has Controller capability, but is not currently the Active Controller.

status byte

A byte of information returned from a remote device that shows the current state and status of the device. If the device follows IEEE-488 (GPIB) conventions, bit 6 of the status byte indicates whether the device is currently requesting service.

symbolic name

A name corresponding to a single interface. This name uniquely identifies the interface on this Controller or gateway. When there is more than one interface on the Controller or gateway, each interface must have a unique symbolic name.

System Controller

One Controller on a GPIB is the System Controller. This is a master Controller; it has the ability to demand control and to assert the IFC (Interface Clear) and REN (remote enable) lines.

system tray

See **notification area**.

Talker

A device that transmits data onto the bus when instructed (addressed to talk).

task guide

The information and logic represented in the left pane of the Connection Expert window. The task guide provides links to actions and information that help guide you through the most common I/O configuration tasks.

taskbar notification area

See **notification area**.

test system

An entire test setup including a controller (often a PC), instruments, interfaces, software, and any remote controllers, instruments, and interfaces that are configured to be used as part of the system.

thread

An operating system object that consists of a flow of control within a process. A single process may have multiple threads, each having access to the same data space within the process. Each thread has its own stack, and all threads may execute concurrently (either on multiple processors, or by time-sharing a single processor).

ViFind32

A console application that uses the viFindRsrc and viFindNext VISA functions to enumerate all resources visible to VISA. This application is useful for verifying that all expected interfaces have been configured by Connection Expert, and that the expected devices have been attached. ViFind32 is part of the Agilent IO Libraries Suite.

virtual instrument

A name given to the grouping of software modules (such as VISA resources with any associated or required hardware) to give them the functionality of a traditional stand-alone instrument. Within VISA, a virtual instrument is the logical grouping of any of the VISA resources. The VISA Instrument Control Resources Organizer serves as a means to group any number of any type of VISA Instrument Control Resources within a VISA system.

VISA

Virtual Instrument Software Architecture. VISA is a standard I/O library that allows software from different vendors to run together on the same platform. Agilent VISA is part of the Agilent IO Libraries Suite.

VISA address

A resource descriptor that can be used to open a VISA session.

VISA alias

A string that can be used instead of a resource descriptor in VISA programs. Using VISA aliases rather than hard-coded resource descriptors makes your programs more portable. You can define VISA aliases for your instruments in Connection Expert.

VISA COM

The *VXIplug&play* specification for a COM-compliant VISA I/O library and its implementation. Agilent VISA COM is part of the Agilent IO Libraries Suite.

VISA Instrument Control Resources

The VISA definition of device-specific resource classes. VISA Instrument Control Resources include all VISA-defined device and interface capabilities for direct, low-level instrument control.

VISA name

The prefix of a VISA address, also called the **VISA interface ID**. The VISA name specifies the interface.

VISA resource manager

The part of VISA that manages resources. This management includes support for opening, closing, and finding resources, setting attributes, retrieving attributes, and generating events on resources.

VISA resource template

The part of VISA that defines the basic constraints and interface definition for the creation and use of a VISA resource. Each VISA resource must derive its interface from the VISA resource template.

VXI Resource Manager

A software utility that initializes and prepares a VXI system for use. The VXI Resource Manager is part of the Agilent IO Libraries Suite.

Windows notification area

See **notification area**.

Glossary

Index

A

- addressing
 - addressing device sessions, 34
 - devices, 34
- Agilent 488, 143
- Agilent web site, 12
- attributes
 - setting VXI trigger lines, 126
 - VXI, 125

B

- buffers
 - formatted I/O, 52

C

- callbacks and events, 56, 64
- closing device sessions, 39
- conversion, formatted I/O, 43

D

- declarations file, 31
- default resource manager, 32
- device sessions
 - addressing, 34
 - closing, 39
 - opening, 32

E

- enable events for callback, 66
- enable events for queuing, 74
- event handler, 66
- events
 - callback, 56, 64
 - enable for callback, 66
 - enable for queuing, 74
 - handlers, 56
 - hardware triggers, 56

- interrupts, 56
- queuing, 56, 73
- SRQs, 56
- wait on event, 75
- examples
 - Checking Instrument Errors, 79
 - Determining Window Mapping, 126
 - Enabling a Hardware Trigger Event, 67, 74
 - Example C/C++ Source Code, 15
 - Exception Events, 82
 - Exclusive Lock, 86
 - GPIB-VXI (E1406A) Interface, 98
 - Installing an Event Handler, 66
 - MEMACC Resource Program, 119
 - Opening a Device Session, 133
 - Opening a Resource Session, 33
 - Opening a Session, 37
 - Printing Error Code, 78
 - Reading a VISA Attribute, 29
 - Receiving Data From a Session, 51
 - Searching VXI Interface for Resources, 41
 - SRQ Callback, 70
 - Trigger Callback, 68
 - Trigger Event Queuing, 75
 - Using Array Size Modifier, 47
 - Using Non-Formatted I/O Functions, 54
 - Using the Callback Method, 64
 - Using the GPIB-VXI Interface (Low-Level) Memory Functions, 110
 - Using the Precision Modifier, 45
 - Using the Queuing Method, 73
 - Using the VXI Interface (High-Level) Memory Functions, 103

- Using the VXI Interface (Low-Level) Memory Functions, 109
- Using viPeek16, 108
- VXI (E8491B) Interfaces, 96

F

- field width, 44
- finding resources, 39
- formatted I/O
 - buffers, 52
 - conversion, 43
 - field width, 44
 - functions, 42
- functions
 - formatted I/O, 42

G

- GPIB interfaces, introduction, 92
- GPIB-VXI
 - attributes, 125
 - high-level memory functions, 102
 - low-level memory functions, 106
 - register programming, 100, 106
 - setting trigger lines, 126
- GPIB-VXI interfaces overview, 97

H

- handlers, 56
 - event, 66
 - installing, 65
 - prototype, 66
- hardware triggers and events, 56
- header file, visa.h, 31
- high-level memory functions, 100
- high-level memory functions for VXI, 100, 102

Index

I

installing handlers, 65
interrupts and events, 56

L

LAN
 hardware architecture, 130
 interfaces overview, 130
locking, 33, 84
locks
 using, 84
low-level memory functions, 106
low-level memory functions for
 VXI, 106

M

MEMACC attribute
 descriptions, 121
memory functions, high-level, 100
memory functions, low-level, 106

N

NI-488, 143
non-formatted I/O
 mixing with formatted I/O, 53

O

opening sessions, 32
overview, guide, 8

Q

queuing and events, 56, 73

R

raw I/O, 53
register programming
 high-level memory functions, 100
 low-level memory functions, 106
resource manager, 32
resource manager session, 32
resources
 finding, 39

locking, 84

S

sample code
 See also examples
searching for resources, 39
sessions
 device, 32
 opening, 32
 resource manager, 32
SRQs, 56
starting the resource manager, 32

T

timeout, 33, 75
trigger lines, 127
triggers and events, 56

U

USB
 communicating with instruments
 using VISA, 141
 interfaces overview, 140

V

VISA
 description, 10
visa.h header file, 31
VXI
 attributes, 125
 high-level memory functions, 102
 low-level memory functions, 106
 register programming, 100, 106
 setting trigger lines, 126

W

wait on event, 75
web site, Agilent, 12